

Why?

When? & How?



TO REMOVE WATER SCALE FROM TANK TYPE* GLASS-LINED WATER HEATERS

FOR NON GLASS-LINED TANKS, CONSULT WATER HEATER MANUFACTURER

PRESENTED AS A SERVICE TO THE PLUMBING TRADE BY

A. O. SMITH
WATER PRODUCTS
COMPANY

For many years the importance of establishing an effective preventive maintenance recommendation for tank type water heating equipment has been recognized. Due to a combination of factors, including limited tank access and lack of suitable scale removal products, such a program had not been developed. In addition, the low input, small tank size heaters of the past operated in a generally satisfactory manner for long periods of time with little or no attention.

With the advent of higher input, larger tank size heaters in both commercial and residential models, maintenance has become a problem that must be faced and dealt with to obtain maximum unit life and user satisfaction.

Now, as the result of cleaning product developments and field testing, A. O. Smith presents a preventive maintenance plan for residential and commercial, gas, oil and electric, tank type water heaters.

* Delimiting coil type water heaters: Request Form 4778 "All About Delimiting Coil Type Water Heaters." from your distributor.

SPECIFIC DELIMING INSTRUCTIONS START ON PAGE 5

Why ?

The reasons for recommending the removal of water scale from the tank of a water heater are essentially the same regardless of application or type of heat energy used. Harmful water scale deposits result in:

1. Not enough hot water.

The water scale and silt forms an insulating blanket over the bottom head of the heater which, in gas and oil fired models, is the major source of heat exchange.

2. Extended heating cycle.

Because the bottom head is covered, recovery time is extended causing longer operational periods.

3. Higher utility bills.

Longer burner operation pushes up the bills but not the benefits.

4. Noisy operation.

Gas and oil fired water heaters may rumble and pound as sediment and scale accumulates.

Electric water heater elements could sizzle and hiss as accumulation builds up.

5. Shortened unit life.

Heating elements, and the tank bottom in gas and oil heaters, lose direct contact with the water as scale builds up. Higher operating temperatures reduce unit life, increase repair bills and makes replacement time come sooner.

6. User dissatisfaction.

The water heater user soon becomes dissatisfied with less hot water, slower recovery and higher operating costs. If the maintenance problem is unrecognized or ignored the heater tank or elements could burn out.

From the foregoing it can be seen that water scale and silt accumulations can cause dissatisfaction and element or tank failure.

The amount of calcium and magnesium carbonate (lime) released from water is in direct proportion to water temperature and usage, see chart. The higher the water temperature or water usage, the more lime deposits are dropped out of the water.

Water heater warranties usually state that the tank must be free of excessive scale or lime deposit or that heater leaks must be due to rust, corrosion or other chemical action of water. In other words, in most cases where heater failure is due to dropout of water impurities, the manufacturer's warranty does not apply.

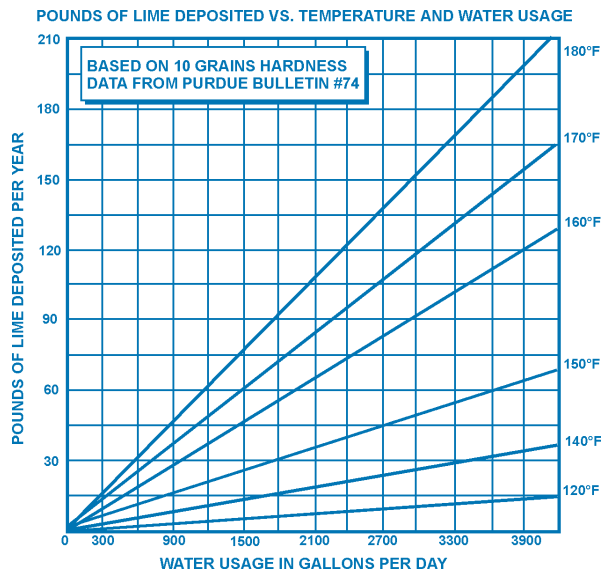

For the purpose of this publication the water impurities referred to and their removal means are listed in Table 1.

TABLE 1 - WATER IMPURITIES

TERMS		DESCRIPTION	REMOVED BY	PROBLEM CAN BE REDUCED OR ELIMINATED BY
Water Scale	*Lime (Hard Water)	Calcium and Magnesium Carbonate.	Deliming with UN•Lime Professional Delimer.	**Water softening or feeding glassy phosphates.
	Other	Silicates, Sulfates Aluminates, etc.	Manually Scraping	Cannot be eliminated but effect can be greatly reduced by periodic deliming with UN•LIME.
Silt		Fine particles of soil or sand suspended in or deposited by water.	Flushing.	Clarifier Filter.

* About 85% of this country's area is served with water containing concentrations of dissolved minerals sufficient to form lime scale

** Excessive lime scale formations can also be reduced by setting the water heater temperature control at the lowest possible temperature which will provide satisfactory hot water service. The usage of water softening equipment greatly reduces the hardness of the water. However, this equipment does not always remove all of the hardness (lime). For this reason it is recommended that a regular schedule for deliming be maintained.

Water scale deposits cause noisy operation because the material buildup, which is porous in initial formation, traps or prevents the rapid release of hot water from the source of heat. Normally, as the water is heated it circulates away from the heat source by gravity as shown in fig. 1.

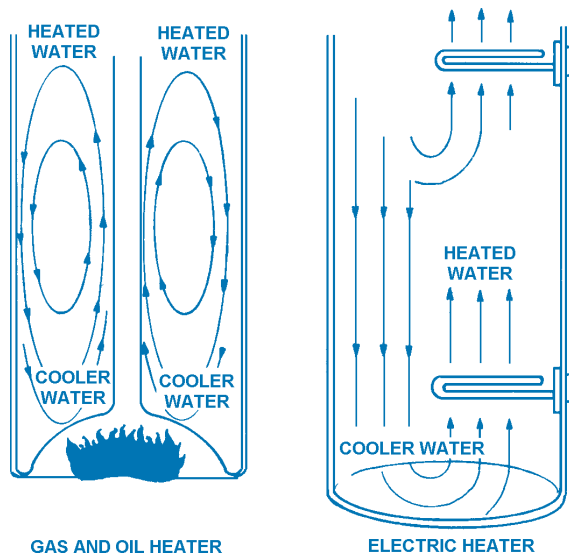

FIGURE 1 - WATER CIRCULATION WITHIN HEATER

Figure 2 shows water pockets in the porous residue. The trapped water is heated above the boiling point of the water in the tank or a drop in the tank pressure occurs, causing audible and sometimes alarming sounds. Table II shows how the boiling point of water varies with a change in pressure.

TABLE II BOILING TEMPERATURE OF WATER UNDER PRESSURE		
Gauge Pressure (Lbs./In. ²)	Temperature	
	(°F)	(°C)
Atmosphere, Sea Level	212	100
20	259	126.1
30	274	134.4
40	287	141.6
50	297	147.2
60	307	152.8
70	316	157.8
80	324	162.2
90	331	166.1
100	338	170

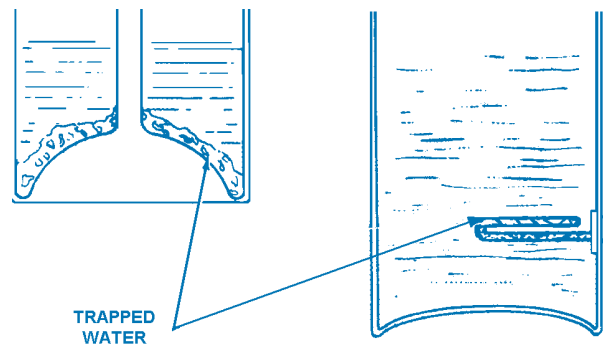

FIGURE 2 - POROUS MATERIAL "TRAPS" WATER

Prolonged operation without cleaning will cause the water scale to solidify and the noise may disappear. However, failure of the tank or elements is imminent.

Heater failure due to excessive lime buildup voids most warranties.

Anode Rod Inspection

The anode rod is used to protect the tank from corrosion. Most hot water tanks are equipped with an anode rod. The submerged rod sacrifices itself to protect the tank. Instead of corroding the tank, water ions attack and eat away the anode rod. This does not affect the water's taste or color. The rod must be maintained to keep the tank in operating condition.

Anode deterioration depends on water conductivity, not necessarily water condition. A corroded or pitted anode rod indicates high water conductivity and should be checked and/or replaced more often than an anode rod that appears to be intact. Replacement of a depleted anode rod can extend the life of your water heater. Inspection should be conducted by a qualified technician, and at a minimum should be checked annually after the warranty period.

NOTE: Anode rod inspection may need to be made more frequently in areas subject to acid rain that obtains their water supply from surface water as the low pH will accelerate anode activity.

CAUTION: Close cold water inlet valve serving heater and open nearby hot water faucet to relieve the pressure in the heater before attempting to remove anode(s) for inspection.

When ?

When to clean out water scale or silt is explained below. The important point to remember is that while the noise is heard the residue is loose and relatively easy to remove. However, once solidified, the accumulations can still be removed.

Aside from monthly tank flushing performed by opening the drain valve (with the water inlet valve left open to maintain pressure in tank), and allowing the water to flow until it runs clean; maintenance should be as indicated until experience indicates the interval for a given operation should be changed ...to a shorter or longer interval.

Changes in water hardness, hot water usage and outlet water temperature may affect the lime buildup in the heater or on the elements. Therefore changes in any of these factors may require deliming to be done on a different schedule.

Gas and Oil-fired Units

The depth of lime buildup should be measured periodically. Heaters equipped with cleanouts will have about 2" of lime buildup when the level of lime has reached the bottom of the cleanout opening. Heaters without cleanouts will have about 1" of lime buildup if it has reached the drain valve opening. A schedule for deliming should then be set up, based on the amount of time it would take for a 1" buildup of lime. It is recommended that the water heater initially be inspected after 6 months.

Example 1:

If initial inspection after 6 months shows 1/2" of lime

accumulation. Therefore, the heater should be delimed once a year.

Example 2:

If initial inspection after 6 months shows 2" of lime accumulation. Therefore, the heater should be delimed every 3 months.

Electric Units

A hissing sound may be heard as lime scale builds up on the residential water heater elements. When this is noticed, the elements should be removed and delimed.

Commercial water heater elements should be delimed as determined by periodic inspections. If elements are limed, a shorter interval between inspections should be scheduled.

How ?

SERVICING A WATER HEATER REQUIRES ABILITY EQUIVALENT TO THAT OF A LICENSED TRADESMAN IN THE FIELD INVOLVED. PLUMBING, AIR SUPPLY AND ELECTRICAL WORK ARE REQUIRED.

General

As shown in Table I, lime and magnesium scale can be removed by deliming with UN•LIME®. UN•LIME is a non-muriatic patented food grade chemical specially formulated for descaling water heaters, heating, cooling, evaporation and humidification equipment.

Other types of scale are removed by manually scraping the tank bottom or the heating elements. Generally the scale removal is made easier through the use of UN•LIME Professional Delimer.

Silt is removed by stirring the accumulation and then flushing it out with water.

Deliming

The deliming process can be accomplished by the UP-N-DOWN® Kit method or by means of a standpipe.

The only product recommended by A. O. Smith for professional deliming of tank type heaters is UN•LIME Delimer, see back cover

The amount of UN•LIME Professional Delimer recommended in Table III is based upon approximation of various models. The table may be used only as a guide for applying UN•LIME to all makes and models of water heaters.

UN•LIME should be used undiluted. Because deliming compounds dissolve sacrificial-type anodes used in most water heaters, it is important that solution be kept below the level of the anode rod, fig. 3. Magnesium and aluminum are typical sacrificial anode materials.

UN•LIME is harmless to all other internal parts of water heaters.

! DANGER

KEEP ALL DELIMERS AWAY FROM SACRIFICIAL-TYPE ANODE RODS TO PREVENT THE FORMATION OF FLAMMABLE AND EXPLOSIVE GAS. CHECK TO BE SURE THERE ARE NO ANODES IN THE TANK BOTTOM. (SOME VERTICAL MODEL COMMERCIAL ELECTRIC HEATERS, 125 GALLON SIZE AND LARGER, HAVE ANODES IN THE TANK BOTTOM).

- **NOTE** - Powered anodes (chemically-inert electrodes with power externally applied) do not form gas if in contact with delimer. The anode power supply should be disconnected during deliming. Be sure to reconnect power after restoring the heater to service.

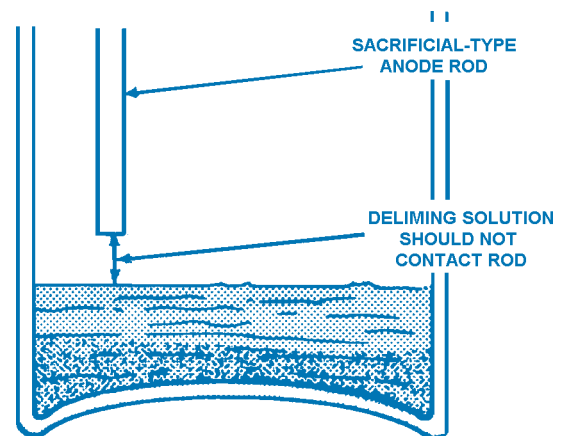

FIGURE 3 - DELIMER SHOULD NOT CONTACT SACRIFICIAL-TYPE ANODE

TABLE III - UN•LIME RECOMMENDATIONS BY SIZE AND TYPE OF WATER HEATER

RECOMMENDED USAGE	DELIMER REQUIRED	KIT INCLUDING DELIMER	UN•LIME DELIMER ONLY
Gas, Electric and Oil Residential/Commercial Tank Type Heaters smaller than 30 Gals.	2 Gallons UN•LIME	N/A	Part No. 4763-P4 (1 Gal., case of 4)
Gas, Electric and Oil Residential Tank Type Heaters from 30 to 66 Gals. Storage Capacity	3 Gallons UN•LIME	4813-3 (w/3 Gals.)	Part 4763-P4 (1 Gal., case of 4)
Gas, Electric and Oil Residential Tank Type Heaters over 66 Gals.through 100 Gals. Storage Capacity	5 Gallons UN•LIME	4813-5 (w/5 Gals.)	Part No. 4813 (5 Gallon Jug)
Gas, Electric and Oil Commercial Tank Type Heaters from 30 to 100 Gals. Storage Capacity	5 Gallons UN•LIME	4813-5 (w/5 Gals.)	Part No. 4813 (5 Gallon Jug)

NOTE: For all commercial water heaters over 100 gallons, consult factory for required amount of delimer.

IMPORTANT: Keep UN•LIME below the level of the anode rod(s), see DANGER paragraph above Figure 4 on Page 4.

UP-N-DOWN TRANSFER KIT FOR DELIMING GAS, ELECTRIC AND OIL TANK TYPE WATER HEATERS WITH UN•LIME DELIMER

• **FOR PROFESSIONAL USE ONLY** •

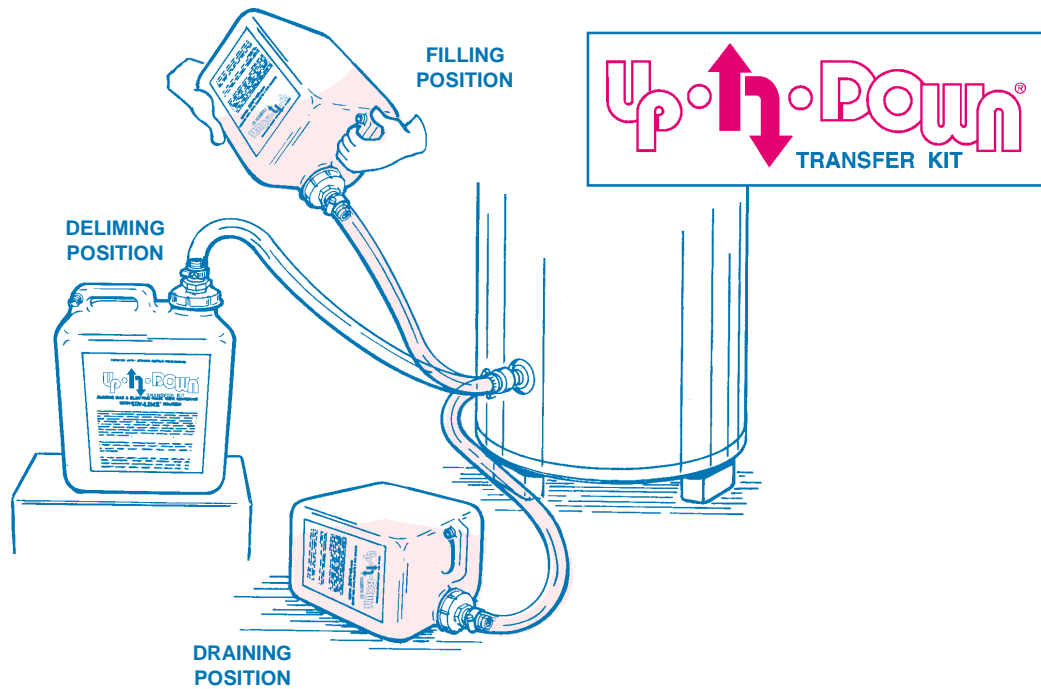

FIGURE 4

Preparation

CAUTION: DO NOT SMOKE OR HAVE OPEN FLAME OR SPARKS IN VICINITY OF HEATER. DO NOT MIX UN-LIME WITH OTHER CHEMICALS. DO NOT ALLOW CONTACT WITH MAGNESIUM, ALUMINUM OR GALVANIZED METALS.

CAUTION: CONTAINS PHOSPHORIC ACID. IN CASE OF EXTERNAL CONTACT, FLUSH WITH COOL WATER.

IF IRRITATION PERSISTS, GET MEDICAL ATTENTION. IF SWALLOWED, GIVE 1 OR 2 GLASSES OF WATER OR MILK AND CALL PHYSICIAN.

GET IMMEDIATE MEDICAL ATTENTION FOR EYES. KEEP OUT OF REACH OF CHILDREN.

NOTE: THE USE OF RUBBER OR NEOPRENE GLOVES IS RECOMMENDED, ESPECIALLY IF YOU HAVE ANY OPEN SORES OR CUTS TO AVOID UNNECESSARY IRRITATION OR DISCOMFORT.

THE FOLLOWING INSTRUCTIONS ARE FOR DELIMING GAS AND OIL-FIRED TANK TYPE WATER HEATERS. (SEE SUPPLEMENTAL INSTRUCTIONS FOR DELIMING ELECTRIC TANK TYPE WATER HEATERS AND ELEMENTS ON PAGE 8.)

Tank type gas and oil fired water heaters (Standing pilot or Electronic models)

1. Turn off fuel and/or power supply to heater. Also, turn off power to any electrical device or equipment, which is attached, or part of the system.
2. Open hot water side of faucet closest to heater and allow water to run until it is cool enough to handle safely. Leave faucet open throughout step 22. **NOTE:** If faucet is used for cold water after step 3, temporarily turn off hot side until cold water is shut.
3. Close cold water inlet valve to heater.
4. Connect hose to drain valve at bottom of heater and start draining heater into suitable floor drain area.
5. Remove relief valve while heater is draining. **NOTE:** Do not replace relief valve until deliming is completed. Relief valve opening will also act as a vent in case of possible contact between the delimer and the anode rod(s), which may produce flammable hydrogen-air mixtures.

CAUTION: Keep open flame and/or sparks away from relief valve opening and/or other tank openings. Do not smoke near any tank openings.

6. If relief valve appears to be limed-up, place it in a clean glass or plastic container adequate in size so that you can pour enough UN•LIME® into the container to cover the valve and allow space for foaming. When foaming stops, run fresh cool water into the container and rinse the relief valve for a few minutes. Reinstall valve at step 21.
7. If heater does not drain completely after a reasonable length of time, turn off the main water supply valve to stop water from entering the tank due to a by-pass problem or defective cold water inlet valve. Also, check for clogged drain valve opening. Heater must be completely drained before introducing UN•LIME.

NOTE: ADEQUATE DRAINAGE SHOULD BE PROVIDED THROUGHOUT STEP 8.

8. After heater has been completely drained, *remove the drain valve and place a clean short plastic bucket next to the drain valve opening.

***NOTE:** When cleaning heaters with cleanout covers, do not remove drain valve until cleanout cover is reinstalled.

We recommend the following options:

Residential type heaters –

- Partially open the cold water inlet valve to allow time to accomplish the following and then close the valve.
- While the water is being run through the tank, insert a stiff wire, copper tube flattened at one end or an opened wire coat hanger through the drain valve opening and scrape out any loose deposits of scale or sediment. This is an economical way to avoid unnecessary usage of the deliming solution.
- Repeat the opening and closing of the cold water inlet valve as necessary but be sure the heater is completely drained when ready to introduce the UN•LIME.

NOTE: If previously used, rinse out the plastic bucket and put it back next to the drain valve opening.

Commercial or Residential heater with cleanout cover-

- Remove the cleanout cover and place a clean plastic bucket next to the cleanout opening.
- Run water through the tank in the same manner described above for residential heaters but use the cleanout opening instead of the drain valve opening to remove loose scale and sediment.
- Upon completion, reinstall the cleanout cover and use a new cleanout cover gasket.
- Rinse out the bucket, remove the drain valve and place the bucket next to the drain valve opening.

9. Preparation of the Up-N-Down® Transfer Kit:

- (A) Install the long plastic male adapter insert fitting into the drain valve opening of heater after applying Teflon tape or paste to threads. Tighten firmly by hand and use wrench or adjustable pliers to check for secure connection. Do not over tighten to avoid damage to threads and fittings. (Figure 5)

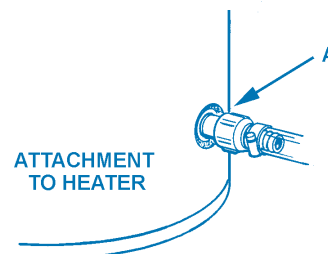

FIGURE 5

- (B) The Up-N-Down Transfer Kit must be vented during deliming to avoid collapsing the plastic container. Unscrew and save the plastic vent cap covering the plastic membrane located at the side of the kit handle. Pierce or cut out the membrane being careful not to damage the threads so that the vent cap can be replaced after the kit is washed out when deliming is completed. (If container does not have vent cap in handle, drill a 3/16" hole through top of handle and install stainless steel screw). Remove screw during deliming. (Figure 6)
- (C) Cut out the plastic membrane located in the 3/4" I. P. T. opening which is the center of the threaded cap located at the top of the kit. Be careful not to damage the threads since this opening is used for connecting the short plastic male adapter insert fitting for deliming and also for sealing the container with the 3/4" plastic plug for storage after washing out the kit. (Figure 6)
- (D) Install the short plastic male adapter insert fitting into the 3/4" I. P. T. opening of the screw cap at the top of the kit after applying Teflon tape or paste to the threads. Tighten firmly by hand, use wrench or adjustable pliers to check for secure connection. (Figure 6)

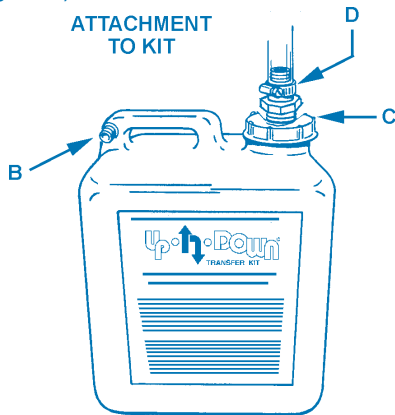

FIGURE 6

- 10. Stand the Up-N-Down Transfer Kit (upright position) at floor level next to the water heater.
- 11. Place loose hose clamp on one end of the 3' length of 3/4" plastic tube and push tubing over barbed section of the long plastic male adapter insert fitting at water heater drain valve opening. Tighten hose clamp to secure connection. (Figure 5)
- 12. Place loose hose clamp at other end of the 3' length of 3/4" plastic tubing and push tubing over barbed section of the short plastic male adapter insert fitting at the 3/4" threaded cap at top of kit. Tighten hose clamp to secure connection. (Figure 6) **NOTE:** Check to make certain all connections are secure at both heater and kit, kit handle is vented and relief valve on heater has been removed. Remember, do not reinstall relief valve until deliming is completed, heater has been flushed and condition of relief valve has been checked.

- 13. Raise the Up-N-Down Transfer Kit in a horizontal position facing the heater high enough above the drain valve opening so that the UN-LIME empties into the heater. Upon contact with the lime scale deposits, foaming should be evident by sight and/or sound. (Figure 7)

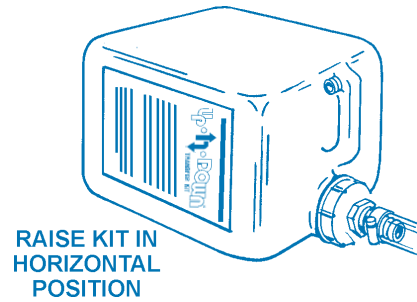

FIGURE 7

Approximately every 5 minutes lower and raise the Up-N-Down® Transfer Kit in the horizontal position to allow deliming solution to enter and drain out of the tank. This action provides agitation, especially in the corners and around the flue bottoms to help speed up cleaning action of the tank.

HELPFUL HINT: Place the UN-LIME® shipping container on its side on the floor next to the heater to be used as a base to elevate the Transfer Kit above the drain valve level. After you have emptied the UN-LIME from the Kit into the heater (UP position), place the now empty Transfer Kit in an upright (vertical) position on the carton or other adequate base to be used for the rest or holding (contact time) period of approximately 5 minutes before you lower the Kit to the floor level (DOWN position) to transfer the solution back into the Kit. (Figure 8)



FIGURE 8

Repeat the up and down procedure until foaming stops. Normally, scale removal can be completed within one hour. However, in cases of severe build-up of lime and sediment, after completing steps 14 through 17, repeat procedure with fresh solution as necessary.

14. When delimiting is completed, lay the Up-N-Down Transfer Kit on the floor in the horizontal position to allow the spent solution to drain back into the Kit. After this is accomplished, change the position of the Kit from horizontal to an upright (vertical) position making certain all of the solution remains in the Kit. (DO NOT RAISE OR ELEVATE THE KIT ABOVE DRAIN VALVE LEVEL.)
15. Place a clean plastic bucket (refer to step 8) next to the drain valve opening to prevent any spillage prior to disconnecting the Kit and flushing the heater.
16. Loosen hose clamp and remove plastic tubing from the long plastic male adapter insert fitting at drain valve opening. Hold tubing over the plastic bucket so that any solution remaining in the tubing or fitting can be emptied into the plastic bucket.
17. Loosen hose clamp and remove plastic tubing from the short plastic male adapter insert fitting in kit. Perform this near the plastic bucket so that any solution remaining in the plastic tube may be emptied into the plastic bucket. Remove the screw cap at the top of the Kit.
18. Empty the spent Un•Lime from the kit and bucket, and drain any remaining Un•Lime from the heater down a clean, operable, floor drain or into a clean laundry tub drain while running fresh cool water into drain. Also clean out jug thoroughly.

⚠ CAUTION

Prior to draining or disposing of the delimiting solution, check the drain you will be using to make sure it is clean (free of any chemicals, cleaners, debris or any foreign matter) and operating properly. Run copious amounts of fresh, clear, cool water down the drain for at least 10 minutes to make certain it does not back up and is devoid of any odors. If drain empties into sump pit, be sure enough fresh cool water is used to cycle the sump pump at least two times. If drain is not suitable, collect spent solution, store in properly labeled clean vented/open glass, reinforced plastic, poly-lined drum, etc. that can be safely transported to a suitable drain for disposal using the same method as noted above.

19. Replace vent cap at handle of Kit, screw plastic plug into the 3/4" I. P. T. screw cap opening and reinstall cap at top of Kit. Put clean empty kit along with tubing and fittings into shipping carton for future use.
20. *Reinstall drain valve in heater (have a spare brass drain valve on hand in case a plastic or leaking drain valve must be replaced). Attach hose and get ready to flush heater into a suitable floor drain area.

*HELPFUL HINT: For more thorough flushing and larger waterway, install a 3/4 x 4" or longer pipe nipple with hose adapter in place of drain valve to perform following step.
21. Slowly open cold water inlet valve and allow water to run through drain valve opening for about 10 minutes to flush out any remaining solution or loose sediment. (Do not

allow water to overflow through the relief valve opening.) Close cold water inlet valve. Allow all remaining water to drain completely from the tank. Reinstall and/or close drain valve.

22. Before reinstalling relief valve, check to see if relief valve passages are clear. Relief valve lever must freely open and close. Make certain the relief valve probe is intact. If there is any question or doubt about the safe condition of the relief valve, replace with a new code approved relief valve correctly rated for the heater. Install the relief valve with proper discharge pipe.
23. Slowly turn on cold water inlet valve to minimize turbulence of water which will reduce loose sediment from collecting in faucets. Do not turn on main burner, fuel and/or power supply until the heater is filled with water. To make certain heater is filled, allow hot water faucet closest to heater to run for at least 2 minutes or until all air is cleared from water lines. Clean all faucet aerators.

TANK TYPE ELECTRIC WATER HEATERS SUPPLEMENTAL INSTRUCTIONS

1. IMPORTANT! Disconnect and lockout power supply to heater. Also, turn off power to any electrical device or equipment which is attached or part of the system.
2. FOLLOW STEPS 2 THROUGH 8 OF THE GAS AND OIL-FIRED WATER HEATER INSTRUCTIONS AFTER ELECTRICAL POWER HAS BEEN DISCONNECTED.
3. Upon completion of step 8, if you have determined the elements are not burned out after taking the proper tests (prior to delimiting) and you desire to check the elements for lime scale build-up, remove the elements and clean as necessary. (See procedure for cleaning immersion type elements.)

*IT IS RECOMMENDED THAT SERVICE TECHNICIANS CARRY AT LEAST ONE EXTRA GALLON JUG OF UN•LIME® AND ONE CLEAN EMPTY GALLON JUG FOR THE PURPOSE OF DELIMITING THE ELEMENTS. PROCEED AS FOLLOWS:

- Cut off the top of the empty one gallon container and insert the element tubes in to the container but leaving the terminal portion of the element out of the jug.
- Pour the UN•LIME from the one gallon jug into the empty jug containing the element being careful not to allow UN•LIME to contact the element terminal.
- Allow the element to stay in the delimiting solution until the foaming stops and the element appears clean.
- Remove element and rinse with plenty of fresh cool water. Repeat this procedure with the other elements.

- Reinstall the clean elements in the tank. It is advisable to carry a supply of element gaskets since it is good practice to use a new gasket whenever you install a new or delimed element.

* Order Part No. 4763-P4 UN•LIME 1 gal. size plastic jugs (sold 4 per case).

NOTE: Flush out any remaining UN•LIME from the element cleaning container down a suitable floor drain area or into a clean laundry tub drain while you are running fresh cool water. Clean out jug thoroughly so that you can save the container for future use.

 **CAUTION**

Prior to draining or disposing of the deliming solution, check the drain you will be using to make sure it is clean (free of any chemicals, cleaners, debris or any foreign matter) and operating properly. Run copious amounts of fresh, clear, cool water down the drain for at least 10 minutes to make certain it does not back up and is devoid of any odors. If drain empties into sump pit, be sure enough fresh cool water is used to cycle the sump pump at least two times. If drain is not suitable, collect spent solution, store in properly labeled clean vented/open glass, reinforced plastic, poly-lined drum, etc. that can be safely transported to a suitable drain for disposal using the same method as noted above.

4. PROCEED TO STEP 9 OF THE GAS AND OIL FIRED CLEANING DIRECTIONS AND CONTINUE THROUGH STEP 14 WITH THE FOLLOWING POSSIBLE EXCEPTIONS.

NOTE: Because the drain opening on an electric heater tank is lower than on a gas heater tank, additional steps for draining may be required.

- After allowing the Transfer Kit to receive as much of the spent solution as possible, raise the Kit to the upright (vertical) position at ground level.
- Carefully remove the tubing from the barbed insert

fitting at the transfer kit side after loosening the hose clamp.

- Hold up the tubing so that the solution cannot spill out and immediately insert the stopper into the tubing to seal it off. Temporarily place stoppered end of tubing into a clean plastic bucket.
- Empty the spent Un•Lime from the kit and bucket, and by repeating this procedure as further described in this step #4 drain any remaining Un•Lime from the heater down a clean, operable, floor drain or into a clean laundry tub drain while running fresh cool water into drain. Also clean jug thoroughly..

 **CAUTION**

Prior to draining or disposing of the deliming solution, check the drain you will be using to make sure it is clean (free of any chemicals, cleaners, debris or any foreign matter) and operating properly. Run copious amounts of fresh, clear, cool water down the drain for at least 10 minutes to make certain it does not back up and is devoid of any odors. If drain empties into sump pit, be sure enough fresh cool water is used to cycle the sump pump at least two times. If drain is not suitable, collect spent solution, store in properly labeled clean vented/open glass, reinforced plastic, poly-lined drum, etc. that can be safely transported to a suitable drain for disposal using the same method as noted above.

- If any more spent solution can be removed from the tank, stand the empty Transfer Kit in an upright position next to the heater, hold tubing above the liquid level of tank bottom, slowly remove the stopper when tubing is clear of liquid and reconnect tubing to the Transfer Kit.
 - Again, lay the kit down in a horizontal position at floor level so that any remaining solution will drain into the Transfer Kit.
5. After completing, raise Kit in an upright position and CONTINUE AT STEP 15 THROUGH 22 OF THE GAS AND OIL FIRED CLEANING INSTRUCTIONS.

Notes

Supplemental Instructions for Applying UN•LIME Deliming Solution Using Standpipe Method

GAS AND OIL-FIRED TANK TYPE WATER HEATERS

IMPORTANT! Prior to installing temporary standpipe assembly, complete steps 1 through 8 on page 6.

ELECTRIC TANK TYPE WATER HEATERS

IMPORTANT! Prior to installing temporary standpipe assembly, complete steps 1 through 3 on page 8.

CAUTION: As noted in above preliminary steps, remove relief valve while heater is draining. Do not replace relief valve until delimiting is completed. Relief valve opening will also act as a vent in case of possible contact between the delimer and the anode rod(s), which may produce flammable hydrogen-air mixture.

CAUTION: Keep open flame and/or sparks away from relief valve opening and/or any other tank openings including the standpipe opening. Do not smoke near any tank or standpipe opening.

- Using 3/4" N. P. T. fitting and nipples, make up a standpipe arrangement at the heater drain valve opening as shown in figures 9 and 10. Note: the use of PVC or CPVC Schedule 80 plastic fittings and nipples is recommended. Use Teflon tape or paste when making up any threaded connections.

INSERT PLASTIC FUNNEL IN THE STANDPIPE NIPPLE POUR OPENING TO AVOID SPILLAGE.

- Refer to recommended usage table on cover page and slowly pour the proper amount of undiluted UN•LIME® into heater tank through the standpipe. **Note:** The use of safety goggles and protective gloves are recommended, especially while pouring solution into standpipe. If splashing occurs, wash down with plenty of fresh cool water. See cautions on label.
- Allow the solution to remain in the tank until foaming stops, usually within 1 hour.
- Place a clean plastic bucket adequately sized to receive the spent solution under the standpipe tee opening, remove plug and allow UN•LIME to flow out of heater.
- Empty the spent Un•Lime down a clean, operable, floor drain or into a clean laundry tub drain while running fresh cool water into drain. Also clean out jug thoroughly.

⚠ CAUTION

Prior to draining or disposing of the delimiting solution, check the drain you will be using to make sure it is clean (free of any chemicals, cleaners, debris or any foreign matter) and operating properly. Run copious amounts of fresh, clear,

cool water down the drain for at least 10 minutes to make certain it does not back up and is devoid of any odors. If drain empties into sump pit, be sure enough fresh cool water is used to cycle the sump pump at least two times. If drain is not suitable, collect spent solution, store in properly labeled clean vented/open glass, reinforced plastic, poly-lined drum, etc. that can be safely transported to a suitable drain for disposal using the same method as noted above.

- Cautiously observe the tank interior through the drain opening (a small flashlight may be used effectively.) If the interior still shows scale deposits, add fresh delimer and repeat process.
- After delimiting has been completed, follow steps 19 through 22 on page 8.

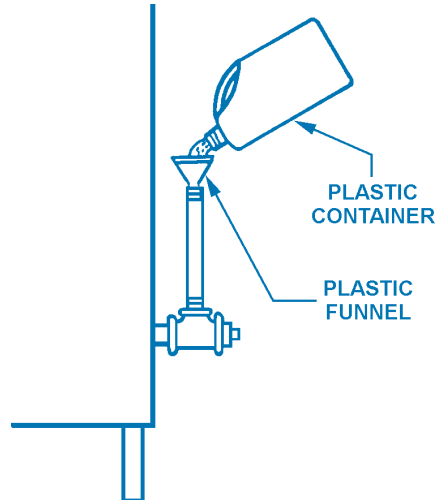

FIGURE 9

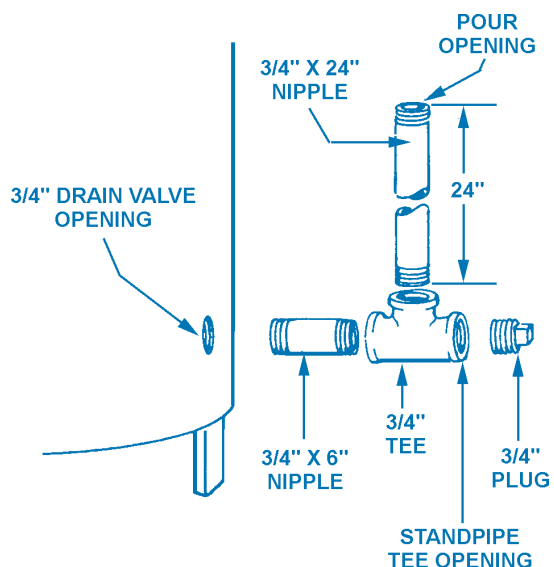

FIGURE 10

UN•LIME

Lime Scale Dissolver

UN•LIME dissolves lime scale wherever hard water is heated or evaporated. Powerful non-muriatic liquid UN•LIME is ready to use without mixing, diluting or heating. Helps stop water heater noise and improve recovery.

For all water heaters, heating, cooling, evaporation and humidification equipment.

Available in 1 and 5 gallon size plastic containers.
The 5 gallon size is also available as UP-N-DOWN delimiting kit, see below.

PART NO. 4763-P4 (1 Gal. Size, case of 4)
PART NO. 4813 (5 Gal. Size)

UN•LIME®

Free delimiting instructions, Form No. 4800

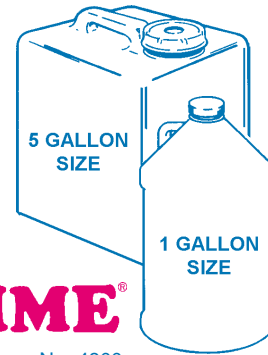

UP-N-DOWN®

Delimiting Kit With UN•LIME

Lime Scale Dissolver

Flow-and-drain method increases chemical reaction, washes out loosened scale. For gas, oil and electric, tank type heaters.

Delimiting kit is reusable. Replenish UN•LIME as necessary.

The UP-N-DOWN Delimiting Kit and hose package assembly are available as listed to the right:

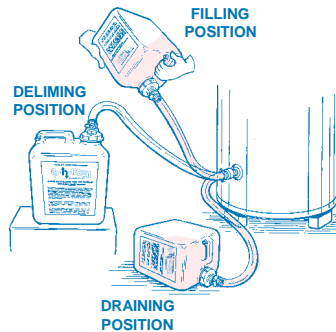

Part No. 4813-3 - Residential Use - Complete kit includes vented plastic jug, tubing, clamps, fittings, instructions and 3 gallons of UN•LIME Delimer for small and medium residential water heaters.

Part No. 4813-5 - Commercial Use - Same as above but includes 5 gallons of UN•LIME Delimer for larger residential and commercial heaters.

Part No. 4813-2 - Replacement hose package only- includes tubing, clamps, fittings and instructions to convert regular Part No. 4813, 5 gallon jug to UP-N-DOWN Delimiting Kit or replace the 4813-3 and 4813-5 hose assembly.

FREE REPLACEMENT PARTS CATALOG

This publication illustrates a full line of Product Preserver's functional parts, relief valves, delimiting products, service aids and tools, intended for all makes of gas and electric residential and light commercial water heaters.

There is a special section containing useful technical data, including orifice size tables and fusing information for servicemen.



FUL-FLO 3/4" FLUSH VALVE

FAST DRAINING - EASY TANK ACCESS USE WITH FLUSHING TOOL AT LEFT

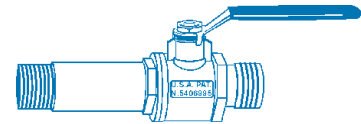

Valve body is copper plated steel and polypropylene, High impact polypropylene head is removable for tank access and delimiting. 3/4" with hose connection.

PART NUMBER	DIMENSIONS (INCHES)	
	"A"	"B"
21126	3	5

FLUSHING TOOL FOR CLEANING TANK BOTTOM

Remove drain valve or use with a full-flo fitting or valve for effective tank flushing when cleaning or delimiting heater. 36" of aluminum tubing with fittings for attachment to 3/4" hose connector.



PART NO. 23315

STANDARD 3/4" BRASS DRAIN VALVES

PART NUMBER	DIMENSIONS (INCHES)	
	"A"	"B"
33937	1 1/16	2 3/8
26273-6	3	4 3/4
26273-7	2	3 3/8
26273-8	1 3/4	3 1/2

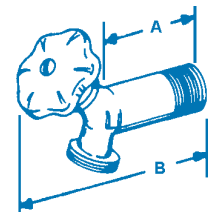

UN-LIME® ORDER IDENTIFICATION GUIDE

UN-LIME® LIME SCALE DISSOLVER, ACCESSORIES & LITERATURE

FOR DELIMING RESIDENTIAL & COMMERCIAL
TANK (STORAGE) TYPE GAS & ELECTRIC WATER HEATERS,
COIL (COPPER) & TUBE TYPE WATER HEATERS

THE FOLLOWING ARE PART NUMBERS AND DESCRIPTIONS:

PRODUCTS

- Part No. 4813** Multi-Purpose 5 Gal. Plastic Container UN-LIME® for Tank & Coil Type Heaters. Can be converted into Hand Operated Deliming Kit for Tank Type Heaters, order Part No. 4813-2 Adapter Pack. For Coil Type Heaters, may be used with standpipe method or with Part No. 4930 Motorized Deliming Pump Kit. Also, most practical and economical for use as Refill for Up-N-Down® Transfer Kits.
- Part No. 4813-2** Replacement/Conversion Adapter Pack only. Contains Tubing and Fittings for Part Numbers 4813, 4813-3 and 4813-5. Adapts to Up-N-Down Transfer Kit and Multi-Purpose Un-Lime containers.
- Part No. 4813-3** Self-Contained Up-N-Down Hand Operated Transfer Kit complete with tubing, fittings and 3 Gals. UN-LIME. For use in Residential Tank (Storage) Type Gas and Electric Water Heater.
- Part No. 4813-5** Self-Contained Up-N-Down Hand Operated Transfer Kit complete with tubing, fittings and 5 Gals. UN-LIME. For use in Commercial Tank (Storage) Type Gas and Electric Water Heaters.
- Part No. P-4763** (Packed 4 Gals. Per Case) Convenient, easy to handle and store, the 1 gallon Plastic jugs are not only basic but also great to have when smaller or additional Amounts of UN-LIME are required. Supplements larger size containers, especially when used for descaling electric elements, relief valves, humidifiers, shower heads and other plumbing, heating, cooling and evaporation equipment.
- Parts No. 4930** Motorized Deliming Pump Kit complete with pump, fittings, hoses and container. Especially compatible with UN-LIME for use in Coil (Copper) Type Water Heaters.

LITERATURE

- Form No. 4800 Rev. 8** Why? When? & How? /UN-LIME Specific Deliming Instructions for use with Up-N-Down Transfer Kit for Tank Type Heaters. (Normally supplied in UN-LIME shipping cartons)
Supersedes Form Nos. 4800 Rev. 7 and 4813-100.

Other A. O. Smith Manual for deliming coil and heat exchanger type water heaters available upon request:

- Form No. 4778*** All about Deliming Coil-Type/Tube-Type Commercial Water Heaters and Hydronic Boilers
*Normally supplied when ordering Part No. 4930 Motorized Deliming Pump Kit

Also, consult the current A. O. Smith Product Preservers Parts Catalog for other deliming products, accessories and water heater parts.



REPLACEMENT PARTS

A. O. SMITH
WATER PRODUCTS
COMPANY

5621 W. 115TH STREET • ALSIP, ILLINOIS 60803
TELEPHONE : 1 800 433-2545 • FAX : 1 800 433-2515

www.hotwater.com

e-mail: www.hotwater.com/parts