

HEAVY-DUTY LARGE VOLUME STORAGE TANKS MODEL HD CUSTOM BUILT

Large volume tanks are designed for storing potable water. Fitting locations of these custom-line tanks match the needs of normal installations plus those for the A. O. Smith Cer-Temp 80® and Shure-Temp™ systems.

FEATURES

SIZES FROM 80 TO 12,500 GALLONS

All tanks are constructed to the requirements of the ASME Code. These ASME Code tanks are available at 125, 150 & 160 PSI working pressure. Consult factory for ASME Code tanks that have greater or lesser working pressures with special configurations or materials.

LINING AND COATINGS

Each lining and coating has particular capabilities and limitations. Thorough investigation on the service life of steel tanks with protective coatings or linings has led to the recommendation of the following linings:

- Glass Lined — All internal surfaces exposed to water are glass lined per ASME HLW Code procedures.
- Cement Lined — Cement lining consists of a specially formulated cement applied over the interior of the vessel. Cement lined tanks are recommended when storing water at 180°F or higher.
- Epoxy Lined — The application of specially formulated epoxy makes this lining suitable for cold or hot water storage.

Please consult the factory for recommendations on the uses of linings for specific applications. All tanks receive one prime coat of paint on external surface. Contact your local A. O. Smith representative for severe or unusual applications that may require other materials.

CATHODIC PROTECTION

Glass lined, cement and epoxy tanks are furnished with anodes designed for maximum protection.

CUSTOM TANK OPENINGS

All tanks will be supplied with the fittings located as indicated on the drawings unless specified otherwise. Custom tank opening sizes and locations can be provided as per your specification.

INSPECTION OPENINGS

- 11"x15" manhole or 4"x 6" handhole are available as options on diameters 36" and below.
- 2 each 2" ASME inspection openings are standard on tanks 36" diameter and below.
- 12"x16" ASME inspection openings are standard on tanks with 42" diameters and above.

TANK OPTIONS

- Manholes • Handholes
- Additional/Custom Tank Openings
- Lifting Lugs
- Angle Legs
- Ring Base
- Horizontal Tank Saddles
- Factory Jacketing and Insulation
- Tank Heaters - Cement and Epoxy Linings

**MODELS
HD-20-80
THROUGH
HD-96-12,500**

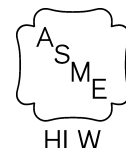
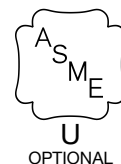



Commercial Storage Tanks

STORAGE TANK SELECTION

Model Number	Diameter	Nominal Approximate O. A. Length	Gallon Capacity	Model Number	Diameter	Nominal Approximate O. A. Length	Gallon Capacity
HD20-80	20"	60"	80	HD54-650	54"	71"	650
HD20-100	20"	72"	100	HD54-750	54"	81"	750
HD24-125	24"	66"	125	HD54-900	54"	95"	900
HD24-140	24"	75"	150	HD54-1,000	54"	105"	1,000
*HD24-175	24"	90"	175	*HD54-1,250	54"	129"	1,250
HD30-175	30"	60"	175	*HD54-1,500	54"	153"	1,500
HD30-200	30"	71"	200	*HD54-1,800	54"	181"	1,800
HD30-250	30"	84"	250	*HD60-800	60"	72"	800
*HD30-300	30"	99"	300	*HD60-1,000	60"	88"	1,000
HD36-250	36"	60"	250	*HD60-1,250	60"	107"	1,250
HD36-300	36"	71"	300	*HD60-1,500	60"	126"	1,500
HD36-350	36"	86"	350	*HD60-1,750	60"	146"	1,750
HD36-400	36"	93"	400	*HD60-2,000	60"	165"	2,000
*HD36-500	36"	122"	500	HD66-1,000	66"	75"	1,000
HD42-375	42"	67"	375	*HD66-1,500	66"	107"	1,500
HD42-450	42"	79"	450	*HD66-2,000	66"	139"	2,000
HD42-500	42"	88"	500	*HD66-2,500	66"	171"	2,500
HD42-600	42"	103"	600	*HD72-2,500	72"	147"	2,500
HD42-700	42"	119"	700	*HD72-3,000	72"	174"	3,000
HD42-800	42"	134"	800	*HD72-3,500	72"	201"	3,500
HD48-500	48"	73"	500	*HD72-4,000	72"	228"	4,500
HD48-600	48"	81"	600	*HD84-4,000	84"	173"	4,000
HD48-700	48"	93"	700	*HD84-5,000	84"	212"	5,000
HD48-750	48"	105"	750	*HD84-6,000	84"	252"	6,000
HD48-900	48"	117"	900	*HD84-8,000	84"	330"	8,000
HD48-1,000	48"	137"	1,000	*HD96-7,500	96"	244"	7,500
*HD48-1250	48"	159"	1,250	*HD96-10,000	96"	319"	10,000
*HD48-1,500	48"	190"	1,500	*HD96-12,500	96"	395"	12,500

NOTE: Above listed tanks are standard sizes only. Other capacity tanks are available. Custom tanks built to your specifications are also available. Consult factory representative.

* Vertical installation requires addition of angle iron legs or ring base.

CUSTOM-LINE STORAGE TANKS (20" THRU 96" DIA. TANKS)

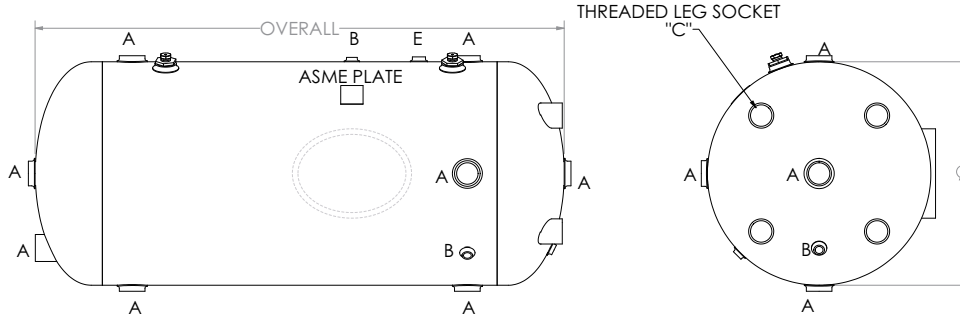

NOTE:

- 1) 54" DIAMETER AND LARGER TANKS MUST BE ORDERED WITH ANGLE LEGS RATHER THAN THREADED LEG SOCKETS FOR VERTICAL INSTALLATIONS.
 - 2) SPECIFY FOR HORIZONTAL OR VERTICAL INSTALLATION.
 - 3) NO LEG SOCKETS PROVIDED ON HORIZONTAL TANKS.
- 2 each 2" ASME inspection openings are standard on tanks 36" diameter and below.
 12"x16" ASME inspection openings are standard on tanks with 42" diameters and above.

CUSTOM-LINE STORAGE TANKS (20" THRU 96" DIA. TANKS)

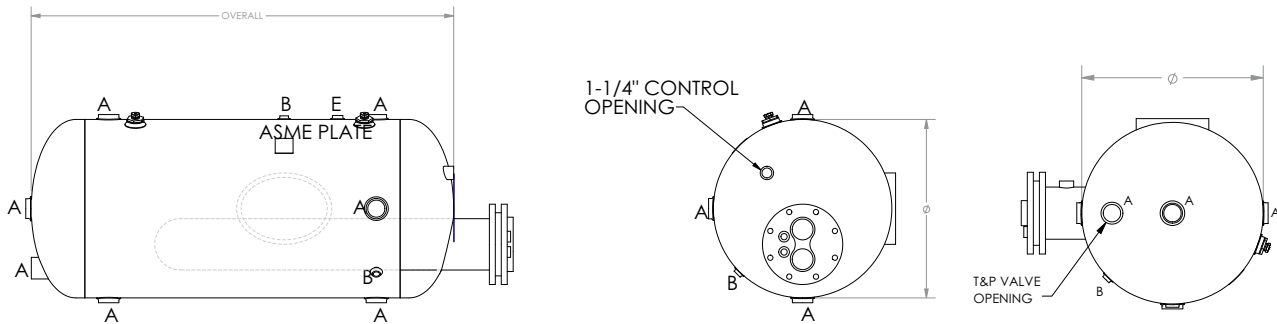

NOTE:

- 1) ADD SUFFIX "ES" FOR SINGLE - WALL OR "ED" FOR DOUBLE - WALL TO MODEL NUMBER WHEN EQUIPPED WITH A TUBE TANK HEATER (i.e.: HD-36-350ES).
- 2) SPECIFY FOR HORIZONTAL OR VERTICAL INSTALLATION.
- 3) NO LEG SOCKETS PROVIDED ON HORIZONTAL TANKS.

ALL DIMENSIONS IN INCHES

DIMENSION CHART					
DIMENSION	A	B	C	D	E
20	2	3/4	1 1/2	6	3/4
24 THRU 36	2 1/2	3/4	2 1/2	8	1
42 AND 48	3	3/4	3	10	1
54 THRU 96	3	3/4	3	10	1

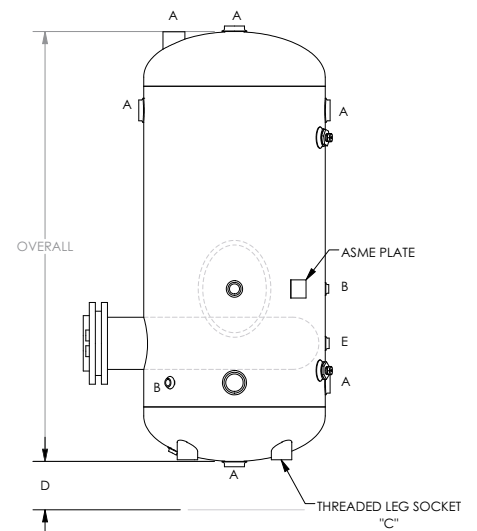



Commercial Storage Tanks

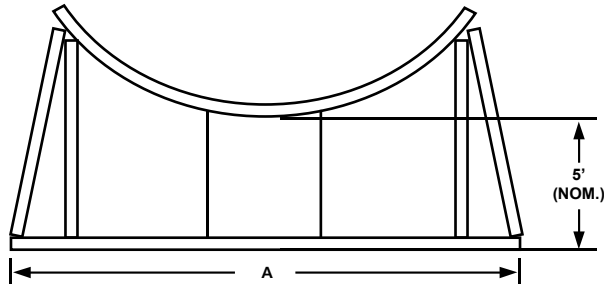
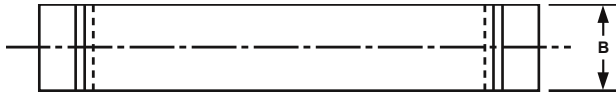

TANK SADDLES

A.O. SMITH PART NO.	TANK DIA.	A	B
P2-2600-20	20	22	6
P2-2600-24	24	26	6
P2-2600-30	30	32	6
P2-2600-36	36	38	6
P2-2600-42	42	44	6
P2-2600-48	48	50	6
P2-2600-54	54	56	8
P2-2600-60	60	62	8
P2-2600-66	66	58	8
P2-2600-72	72	74	10
P2-2600-84	84	86	10
P2-2600-96	96	98	10

FACTORY INSULATION OPTIONS

Factory Jacketed and Insulation

- **INSULATION** — Entire tank is surrounded with high-density fiberglass insulation to reduce costly heat loss; non-sagging and vermin-proof. To meet or exceed the thermal efficiency and/or standby loss requirements of the U.S. Department of Energy and current edition of ASHRAE/IESNA 90.1, depth of insulation cavity requires use of remote bulb-type tank temperature control and thermometer.
- **CABINET** — Heavy gauge steel with high quality powder coat paint provides additional insulating qualities for greater energy savings.
- Adds 6" to the diameter of the tank.



OUTDOOR FOAM INSULATION

- **INSULATION** — Entire tank is sprayed with minimum of 2" high-density polyurethane foam insulation that forms a watertight jacket that is approved for outdoor use. Meets or exceeds the thermal efficiency and standby loss requirements of the U.S. Department of Energy and Current Edition of the ASHRAE/IESNA 90.1.
- Adds 6" to the diameter of the tank.

Note: Minimum foam insulation thickness is 2"; however, since tank is hand sprayed, insulation thicknesses may be greater in some areas giving the finished tank an uneven but watertight surface.

HIGH EFFICIENCY (R-16) FACTORY JACKET AND INSULATION

- **INSULATION** — Meets or exceeds the thermal efficiency and/or standby loss requirements of the U.S. Department of Energy and Current Edition of the ASHRAE/IESNA 90.1. For Green building jobs where maximum energy efficiency is required. Entire tank is surrounded with high-density fiberglass insulation to reduce costly heat loss and save additional energy; non-sagging and vermin-proof. The increased depth of the insulation cavity requires use of remote bulb-type tank temperature control and thermometer.
- **CABINET** — Heavy gauge steel with high quality powder coat paint provides additional insulating qualities for greater energy savings.
- Adds 10" to the diameter of the tank.

SUGGESTED SPECIFICATION

SAMPLE SPECIFICATION FOR CUSTOM-LINE STORAGE TANKS

When jacketed or insulated these models meet or exceed the thermal efficiency and standby loss requirements of ASHRAE 90.1b (current standard).

ASME storage tank to be A. O. Smith Custom-Line model _____. Capacity to be _____ gallons with a diameter of _____ inches. Tank(s) shall be constructed and stamped according to ASME specifications for _____ psi working pressure. Manhole (12"x16"), handhole (4x6) or inspection openings (2-2") shall be installed in accordance with ASME code requirements and manufacturer(s) standard practice. Tank to be constructed of (carbon steel) _____. Lining shall be (glass, epoxy, cement) _____. Tank(s) lined with (glass, cement, epoxy) _____ lining shall be equipped with the number and size of magnesium anode rod(s) sufficient to provide adequate protection for the tank lining. Tank shall be (vertical, horizontal) _____ design and provided with (four) _____ (angle iron legs, threaded leg socket(s)) _____ ring base, _____ saddles.

SAMPLE SPECIFICATION FOR TANK HEATERS

Tank heaters shall be Model No. _____ 3/4" OD 20 gauge copper "U" tubes. Heater to have _____ square feet of heating surface to heat _____ gallons per hour from _____ degrees F to _____ degrees F with heating media of _____ psi steam (or _____ degrees F boiler water). The element shall be constructed so that the entire section can be removed from the tank for cleaning and inspection.

For Technical Information and Automated Fax Service, call 800-527-1953. A.O. Smith Corporation reserves the right to make product changes or improvements without prior notice.