



Residential Gas Hybrid Water Heater

NEXT HYBRID® WATER HEATER

NEXT Hybrid® is the new milestone in water heating—built for the way people ACTUALLY live and use hot water. It combines the best features of tankless and conventional technologies to create a new category of water heating.

ELIGIBLE FOR FEDERAL TAX CREDIT - VISIT WWW.HOTWATER.COM FOR MORE INFORMATION

ENERGY EFFICIENCY

- Patented circulation system delivers 90% thermal efficiency, ensuring maximum heat transfer, saving money on operating costs compared to a standard 78% efficient conventional or 84% tankless gas water heaters.
- Condensing design includes condensate drain trap

HYBRID TECHNOLOGY

- Innovative technology that surpasses existing conventional and tankless designs
- Patented water flow circulation system provides the performance of a tankless unit with extremely quick recovery
- First hour delivery of 189 gallons of hot water
- Smaller than a conventional 50-gallon gas water heater, but with twice the hot water delivery
- Whole-home solution regardless of geography

IMPROVED HOT WATER DELIVERY

- Continuous hot water shower after shower when properly sized for your home
- No minimum flow rate for ignition
- No cold water sandwich
- Delivers hot water faster than tankless
- Internal storage easily handles peak demand

SOPHISTICATED ELECTRONICS

- User-friendly integrated temperature controller with LED numeric display allows for precise temperature settings
- Multiple Lifestyle Modes - Energy Saver, Vacation and Boost modes allow for simple one-touch customization based on specific hot water needs
- Safety lock feature deters unwanted access
- Error code display for easy troubleshooting

LOWER INSTALLATION COSTS

- Utilizes 1/2" gas line standard in most homes today
- Extremely low exhaust temperature enables PVC venting for easier, more economical installations
- Less expensive venting material versus stainless steel venting used with most tankless models
- Hot and cold water connections similar to conventional tank-style models

POWER VENT DESIGN

- Uses inexpensive PVC, CPVC or ABS pipe for exhaust (solid core only). Canadian installations require ULCS636 listed PVC or CPVC pipe for venting.
- Can be vented vertically thru-the-roof or horizontally thru-the-wall
- 2" pipe vents up to 50 equivalent feet
- 3" pipe vents up to 100 equivalent feet

SIX YEAR LIMITED WARRANTY ON HEAT EXCHANGER, TANK AND PARTS

- For complete warranty details, consult written warranty shipped with water heater or contact A. O. Smith Water Products Company.



HYB-90N



ANSI Z21.10.3 CSA 4.3





Residential Gas Hybrid Water Heater

MODEL	FIRST HOUR DELIVERY GALLONS	RECOVERY 90°F RISE GALLONS	INPUT	MANIFOLD PRESSURE			ELECTRICAL CHARACTERISTICS		SHIPPING WEIGHT LBS/KGS
			BTU/HR	GAS TYPE	IN. WC	kPA	VOLTS/HZ	AMPERES	
HYB-90N	189	121	100,000	NAT	4.2	1.05	120/60	2.5	198/90

This gas-fired water heater is design certified by CSA International under American National Standard/CSA Standard for Gas Water Heaters ANSI Z21.10.3 • CSA 4.3 (current edition).

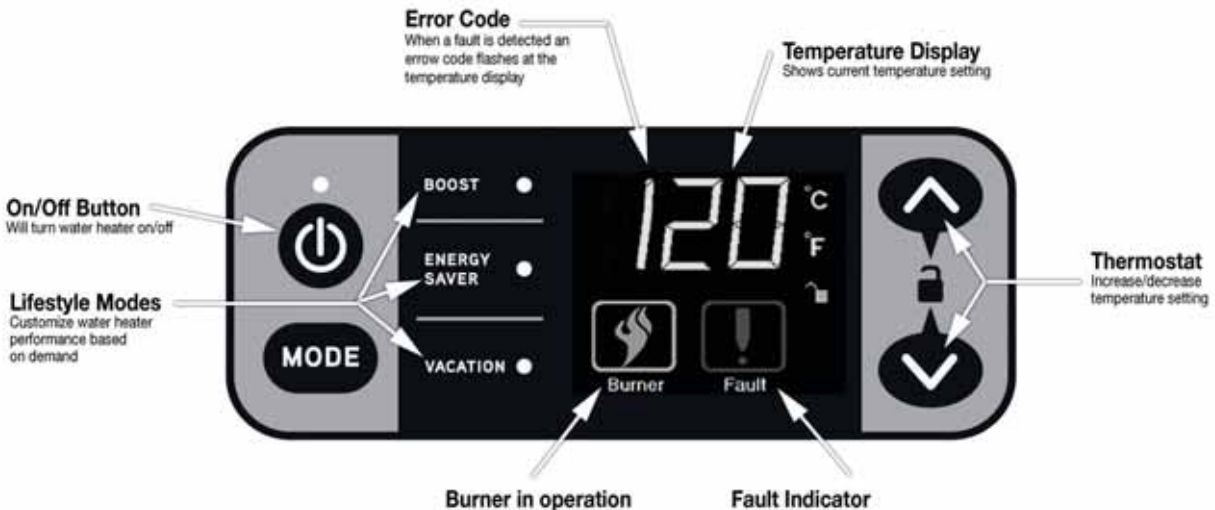
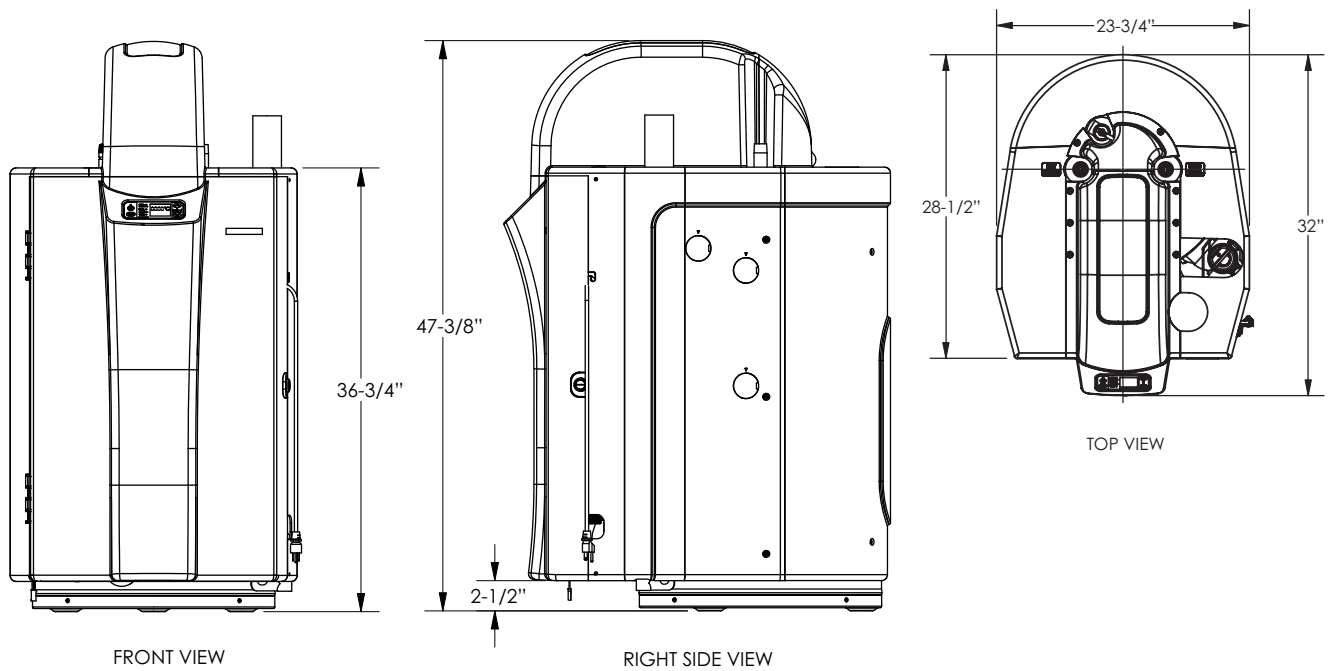

For Technical Information and Automated Fax Service, call 800-527-1953. A. O. Smith reserves the right to make product changes or improvements without prior notice.