

CYCLONE[®] Xi™

96% THERMAL EFFICIENCY VERSATILE POWER DIRECT-VENT

The Cyclone Xi is a light-duty, power direct-vent, fully condensing commercial gas water heater with an internal helical heat exchanger. This helical heat exchanger helps Cyclone Xi achieve 96% thermal efficiency and deliver outstanding hot water output.

HELICAL INTERNAL HEAT EXCHANGER

- Completely surrounded by water in tank, provides much greater heat transfer surface than standard straight flue tube
- Produces 96% thermal efficiency, which saves money on operating costs, increases hot water output compared to standard-efficiency water heaters
- Minimizes standby losses by trapping heat in the tank
- Spiral heat exchanger reduces scale and sediment from forming on water-side surface, which can reduce energy efficiency over time.

VERSATILE POWER DIRECT-VENT DESIGN

- Power Direct-Vent System allows up to 120 feet using PVC, CPVC, ULC S636 PVC/CPVC or ABS pipe. Can be vented vertically thru-the-roof or horizontally thru-the-wall
- 2" pipe, vents up to 20 equivalent feet
- 3" pipe, vents up to 60 equivalent feet
- 4" pipe, vents up to 120 equivalent feet
- Optional concentric vent kit available

CONDENSING DESIGN

- 96% efficient condensing design
- Equipped with condensate drain tee

HIGH OUTPUT WITH SMALL FOOTPRINT

- 22" diameter, combined with 96% efficiency, 50-gallon tank and 100,000 BTU input means Cyclone Xi can be installed in less space than a larger 75-gallon unit, with equal or better performance
- Total height is 68-1/2" to top of unit

SIDE-MOUNTED HOT AND COLD RECIRCULATING TAPS

- Allows Cyclone Xi to be installed as part of combination space heating/water heating applications, or any system requiring a recirculating hot water loop
- Plugs for the recirculating taps are factory installed

ADVANCED ELECTRONIC CONTROL

- Large LCD display
- Precise temperature control
- Advanced diagnostics
- iCOMM™ Compatible - Call 1.888.WATER02 for more information

PERMAGLAS[®] ULTRA COAT™ GLASS LINING

- A. O. Smith exclusive process provides superior protection against corrosion
- Protects all interior tank surfaces including inside and outside of helical heat exchanger

TWO HEAVY-DUTY ANODE RODS

- Provides advanced protection against corrosion

AVAILABLE IN NATURAL GAS AND PROPANE

TOP-FIRED LOW-NOX GREEN CHOICE[®] GAS BURNER

- "Eco-friendly" design reduces NOx emissions and complies with Air Quality Management Districts with similar requirements for NOx emissions

CSA CERTIFIED AND ASME RATED T&P RELIEF VALVE

MAXIMUM HYDROSTATIC WORKING PRESSURE: 150 PSI

CODES AND STANDARDS

- Design-certified by UL (Underwriters Laboratories) according to ANSI Z21.10.3-CSA 4.3 standards governing storage-type water heaters
- These models meet or exceed the thermal efficiency and standby loss requirements of the U.S. Department of Energy and current edition of ASHRAE/IESNA 90.1

BTX-100





**96% THERMAL EFFICIENCY
VERSATILE POWER DIRECT-VENT**

THREE-YEAR LIMITED TANK WARRANTY

■ For complete warranty details, consult written warranty shipped with heater or contact A. O. Smith

SPECIFICATIONS

MODEL NUMBER	BTU INPUT PER HOUR	GALLONS OR LITRES	TANK SIZE	RECOVERY - GALLONS OR LITRES PER HOUR AT DEGREE RISE			SHIPPING WEIGHT
				40°F	100°F	140°F	
				22°C	56°C	78°C	
BTX-100	100,000	Gallons	50	291	116	83	255 lbs
		Litres	189	1102	439	314	115.7 kg's

Maximum Supply Pressure: 14 inches W.C. (3.48kPa) ■ Minimum Supply Pressure for Natural Gas: 3.50" (.87kPa) ■ Minimum Supply Pressure for Propane Gas: 8.00" (1.99kPa)
 Minimum pressure must be maintained under both load and no load (dynamic and static) conditions. ■ Electrical Characteristics - 120V, 60Hz, Amperes <5
 Approved for Canada

DIMENSIONS

BTX-100	A	B	C	D	E	F
INCHES	68-1/2	49-1/4	22	15-3/4	3	8
CM	174	125.09	55.88	40	7.62	20.32

Top inlet and outlet: 3/4" male NPT ■ Side inlet and outlet: 3/4" female NPT ■ Gas inlet: 1/2" NPT ■ Available natural gas and propane

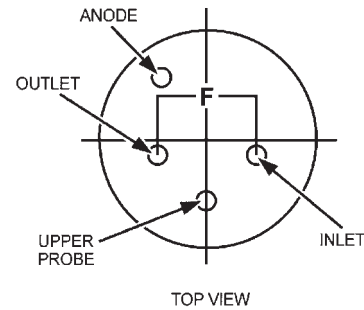
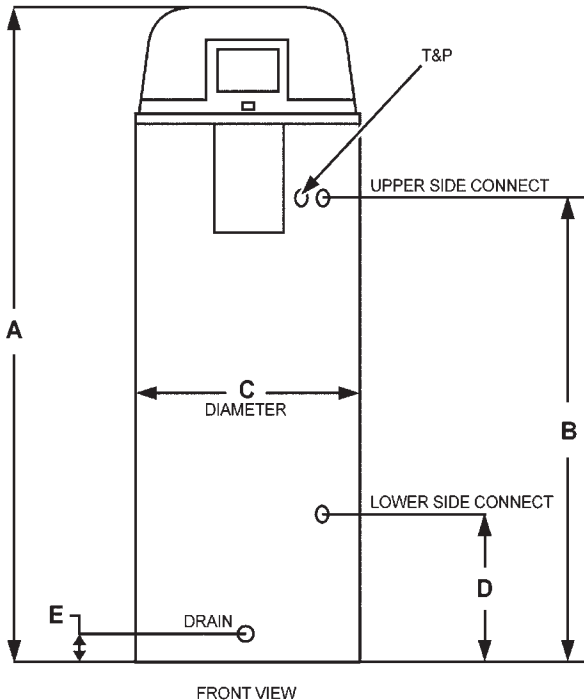

*INSTALL IN ACCORDANCE WITH LOCAL CODES.

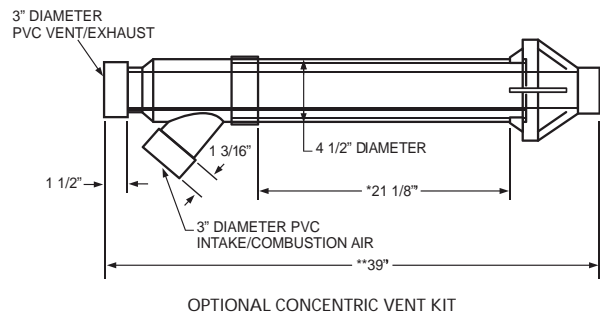

SUGGESTED SPECIFICATION

(Natural or Propane) gas water heater(s) shall be A. O. Smith Cyclone Xi model # BTX-100, with 96% thermal efficiency, a storage capacity of 50 gallons, an input rating of 100,000 BTUs per hour, a recovery rating of 116 gallons per hour at 100°F rise and a maximum hydrostatic working pressure of 150 psi. Water heater(s) shall be of power direct-vent design, using 2", 3" or 4" PVC pipe for horizontal and/or vertical vent runs. Water heater(s) shall have: 1: Seamless, glass lined steel tank construction and a spiral-shaped heat exchanger placed entirely inside the tank, which shall be glass lined on the flue gas side to protect against acidic condensate. 2: Advanced electronic control w/ LCD display and actual diagnostic. 3: A 3-year limited warranty against tank leaks. Water heater(s) shall meet or exceed the thermal efficiency and standby loss requirements of the U.S. Department of Energy and current edition of ASHRAE/IESNA 90.1 and be design-certified by UL (Underwriters Laboratories) according to ANSI Z21.10.3-CSA 4.3 standards governing storage tank water heaters. Water heater should incorporate the iCOMM™ system for remote monitoring, leak detection and fault alert.