

PROLINE® 80 GALLON ELECTRIC

ELECTRONIC THERMOSTAT

- Provides precise temperature control with enhanced sensing for increased comfort and faster water heating response (Max set point 150°F)
- Element “Dry-Fire” protection safeguards the element from damage if the tank is not filled with water on startup
- Diagnostic (dual color) LED light flashes green for normal operation and red fault codes for easy service diagnostics

DUAL INCOLOY® HEATING ELEMENTS

- Two 4,500 Watt Incoloy® stainless steel elements last longer than standard copper elements

HIGHER EFFICIENCY

- Eco-friendly thick non-CFC foam insulation, heat traps and other features combine to yield a high 0.93 Uniform Energy Factor to maximize savings

SMART PORT

- Allows for grid connectivity via an optional CTA-2045 port adapter and 3rd party communication module to provide Demand Response Energy Storage and Time-of-Use savings benefits depending on local utility services offered

DYNACLEAN™ DIFFUSER DIP TUBE

- Helps reduce lime and sediment buildup and maximizes hot water output. Made from long-lasting PEX cross-linked polymer.

COREGARD™ ANODE ROD

- Our anode rods have a stainless steel core that extends the life of the anode rod allowing superior tank protection far longer than standard anode rods

BLUE DIAMOND® GLASS COATING

- Provides superior corrosion resistance compared to industry standard glass lining

ENHANCED-FLOW BRASS DRAIN VALVE

- Our residential water heaters have a solid brass, tamper resistant, enhanced-flow, ball type, drain valve
- Uses a standard female hose fitting that allows for fast and easy draining during maintenance
- Designed for easy operation, this valve includes an integral screwdriver slot that features a ¼ turn (open/close) radius, which not only permits full straight-through water flow but also a quick and positive shut off

CODE COMPLIANCE

- Meets UBC, CEC and HUD National Codes
- Meets the UEF requirements as prescribed by the U.S. Department of Energy in effect as of October 1, 2019

APPROVED FOR MANUFACTURED HOUSING

- All residential electric water heaters are compliant with HUD standards for mobile homes/manufactured housing

CERTIFIED TO UL 174 FOR HOUSEHOLD RESIDENTIAL ELECTRIC WATER HEATERS

CSA CERTIFIED AND ASME RATED T&P RELIEF VALVE

DESIGN-LISTED BY UNDERWRITERS LABORATORIES

- Certified at 300 psi test pressure and 150 psi working pressure
- Listed according to UL 174 standards governing storage tank-type electric water heaters

6-YEAR AND 10-YEAR LIMITED TANK AND PARTS WARRANTY MODELS

- For complete information, consult written warranty or go to hotwater.com



Low Lead Content



HIGH CAPACITY

RESIDENTIAL ELECTRIC WATER HEATERS

Model Number	Nominal Capacity	Rated Storage Volume	First Hour Rating (Gallons)	UEF	Recovery @ 90°F Rise Gallon Per Hour	Element Wattage	Dimensions in Inches			Approx. Shipping Weight (lbs)
							A	B	C	
High Capacity 6-Year Warranty Model										
EGR-80	80	78	80	0.93	21	4500	64-1/2	56	26	198
High Capacity 10-Year Warranty Model										
PGR-80	80	78	80	0.93	21	4500	64-1/2	56	26	198

3/4" water connections on 8" center.

Only available for 240V or 208V applications.

Only available with 4,500 watt elements.

Equipped as dual element only, no single element configurations available.

Dimensions and specifications subject to change without notice in accordance with our policy of continuous product improvement.

SMART PORT MODULE CONNECTION

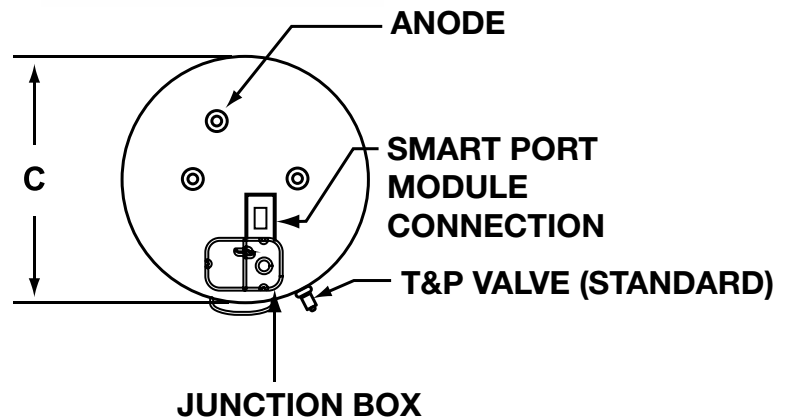
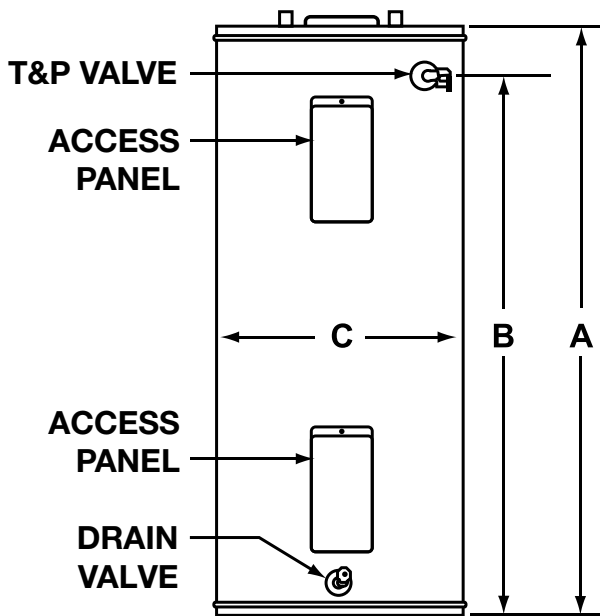

For Technical Information, call 800-527-1953. A. O. Smith Corporation reserves the right to make product changes or improvements without prior notice.