

### EFFEX® HIGH EFFICIENCY COMMERCIAL-GRADE RESIDENTIAL

#### PRESSURIZED COMBUSTION SYSTEM

Exclusive and patented pressurized combustion chamber with an advanced air intake blower delivers superior efficiency. Much like a turbocharger, the blower distributes an optimum air-to-gas mixture pushing exhaust gases through the highly restricted flue baffle. The end result is the most efficient atmospheric gas product on the market with Uniform Energy Factors (UEF) up to 0.72.

#### INSTALLATION FRIENDLY

- Allows for easy replacement of standard atmospheric vent heaters.
- Easily connects to existing B-vent.

#### FAN-ASSISTED, CATEGORY 1 APPLIANCE

- Plugs into standard 110/120V outlet (10 foot power cord included).

#### 24V ELECTRONIC CONTROLS

- Tighter differential for more consistent hot water delivery.

#### ELECTRONIC IGNITION

- The durable hot surface ignitor eliminates pilot relight issues (no standing pilot).

#### LCD USER INTERFACE

- Easy-to-read, eye level display. Simple temperature settings and adjustments. Service diagnostics are in plain text.

#### POWERED ANODE ROD

- Powered anodes are non-sacrificial, so they do not deplete over time. Additionally, they provide exceptional performance in all water conditions.

#### MEETS ENERGY EFFICIENCY REQUIREMENTS FOR MOST GAS UTILITY REBATE PROGRAMS AND IS ENERGY STAR® QUALIFIED

#### DURABLE TAMPER-RESISTANT BRASS DRAIN VALVE

#### DYNACLEAN™ DIFFUSER DIP TUBE

- Helps reduce lime and sediment buildup, maximizes hot water output.
- Made from long-lasting PEX cross-linked polymer.

#### GREEN CHOICE® GAS BURNER

- Patented "Eco-Friendly" Green Choice® gas burner reduces NOx emissions by 33% compared to standard burners and meets low NOx requirements of less than 40ng/j.

#### CSA CERTIFIED AND ASME RATED T&P RELIEF VALVE

#### CODE COMPLIANCE: UBC, CEC, SBCC, CABO, HUD, BOCA NATIONAL CODES, CURRENT EDITION ASHRAE/IES 90.1 AND 2004 NAECA STANDARDS

#### DESIGN-CERTIFIED BY CSA INTERNATIONAL

- According to ANSI Z21.10.1 - CSA 4.1 Standards governing storage-type water heaters.

#### 6-YEAR LIMITED TANK AND PARTS WARRANTY

- For complete information, consult written warranty or go to [hotwater.com](http://hotwater.com)



Model Number	Nominal Gallon Capacity	Rated Storage Volume	First Hour Rating (Gallons)	UEF	BTU Input Gallon Per Hour	Recovery @ 90°F Rise Gallon Per Hour	Dimensions in Inches									Approx. Shipping Weight (lbs)
							A	B	C	D	E	F	G	H	Draft Hood	
GAHH-40	40	38	68	0.66	40,000	43	61-3/4	58	20	13-1/4	8	51-1/2	23-1/4	25	3 or 4	157
GAHH-50	50	48	80	0.72	40,000	43	60-5/8	57-1/8	22	13-1/4	8	50-1/2	25-1/4	27	3 or 4	171

All dimension in inches.

For Canadian models add T25 SMR, i.e. GAHH-40-T25.

Recovery capacity based on actual performance tests.

Water Connections – 3/4" on all models.

Not available in LP gas (Propane).

All models are certified from sea level to 10,100 ft. elevations.

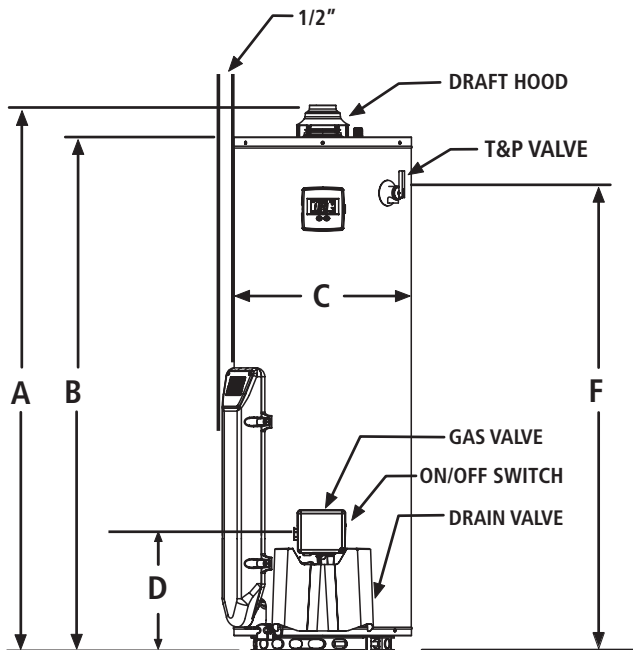

FRONT VIEW

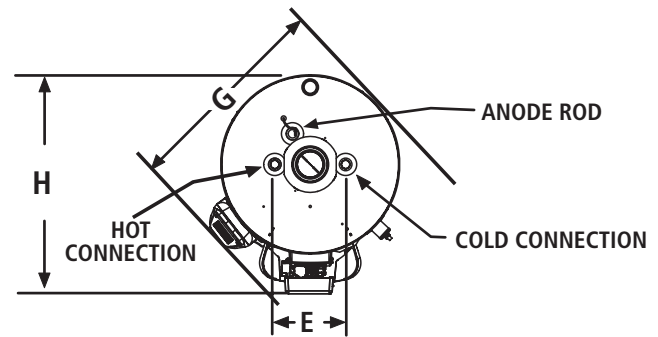

TOP VIEW