

————— FACTORY WIRED
 - - - - - FIELD WIRED

IF ANY OF THE ORIGINAL WIRES AS SUPPLIED MUST BE REPLACED,
 USE ONLY TYPE 105° C THERMOPLASTIC OR ITS EQUIVALENT.

**WIRING DIAGRAMS FOR
TWO LEGEND MODELS
WITH ONE STORAGE TANK
LW-500 AND LB-500
LW-750 AND LB-750
LW-1000 AND LB-1000**

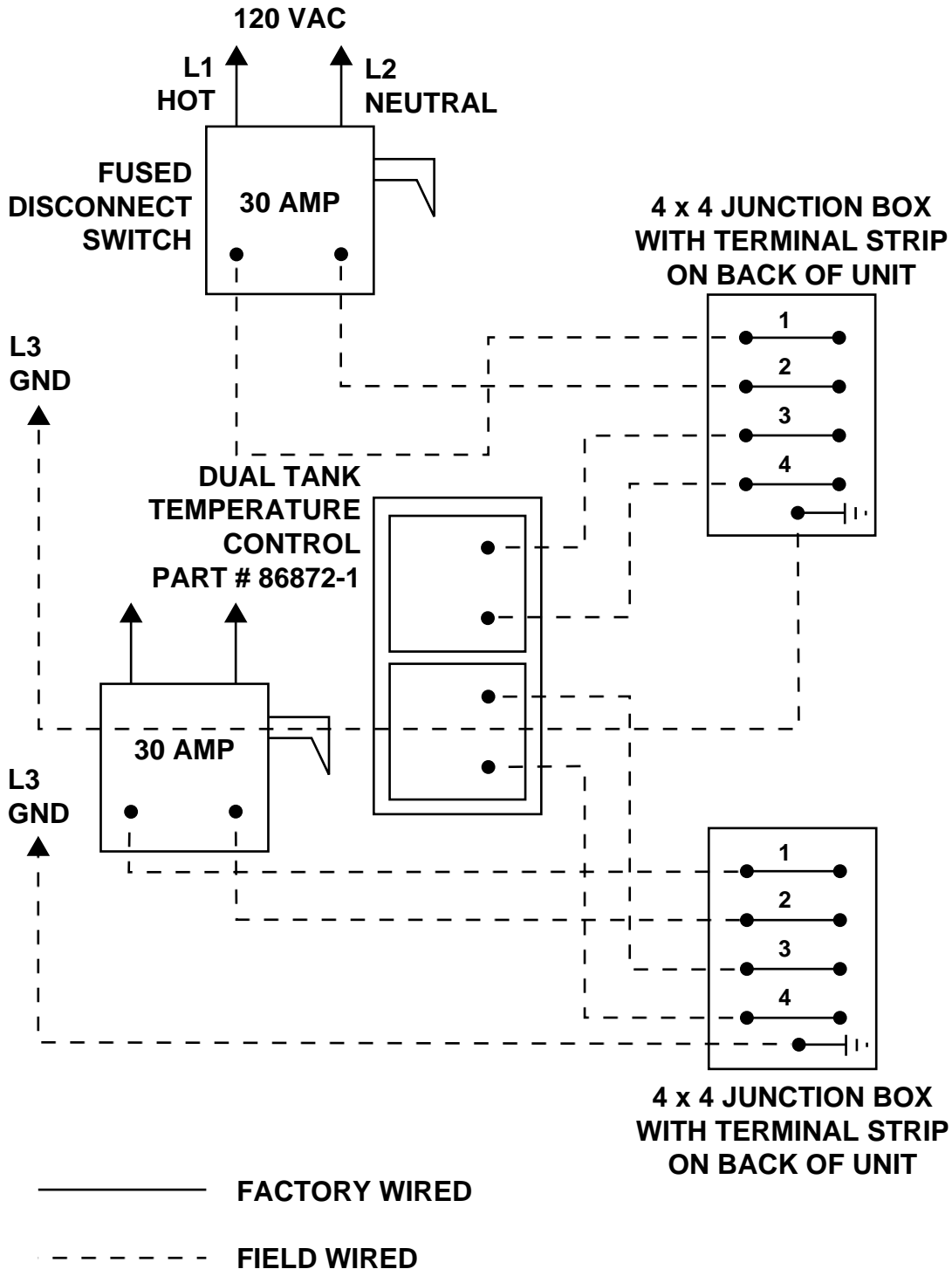

**IF ANY OF THE ORIGINAL WIRES AS SUPPLIED MUST BE REPLACED,
USE ONLY TYPE 105° C THERMOPLASTIC OR ITS EQUIVALENT.**

