

A. O. Smith Commercial boiler installations include a THERMAL BALANCER pump delay shutoff switch. A THERMAL BALANCER is also recommended to be used with each pump motor of a multiple boiler installation.

This motor switch device requires the introduction of 120 VAC current through a temperature controlled operator to its RED wire. The BLACK wire of the delay switch must also be powered by a 120 VAC uninterrupted power source.

CAUTION

The 120 VAC current to the BLACK wire of each THERMAL BALANCER must be from the same leg of a 240 VAC electrical system in a building as the leg that will be powering the RED wire of that same BALANCER.

For load balancing reasons, the power source for controllers of multiple boilers are sometimes split between the legs of a 240 VAC system. In these cases, extreme care should be exercised to see that the power supply for the BLACK and RED wire of each individual delay switch is from the same 120 volt source.

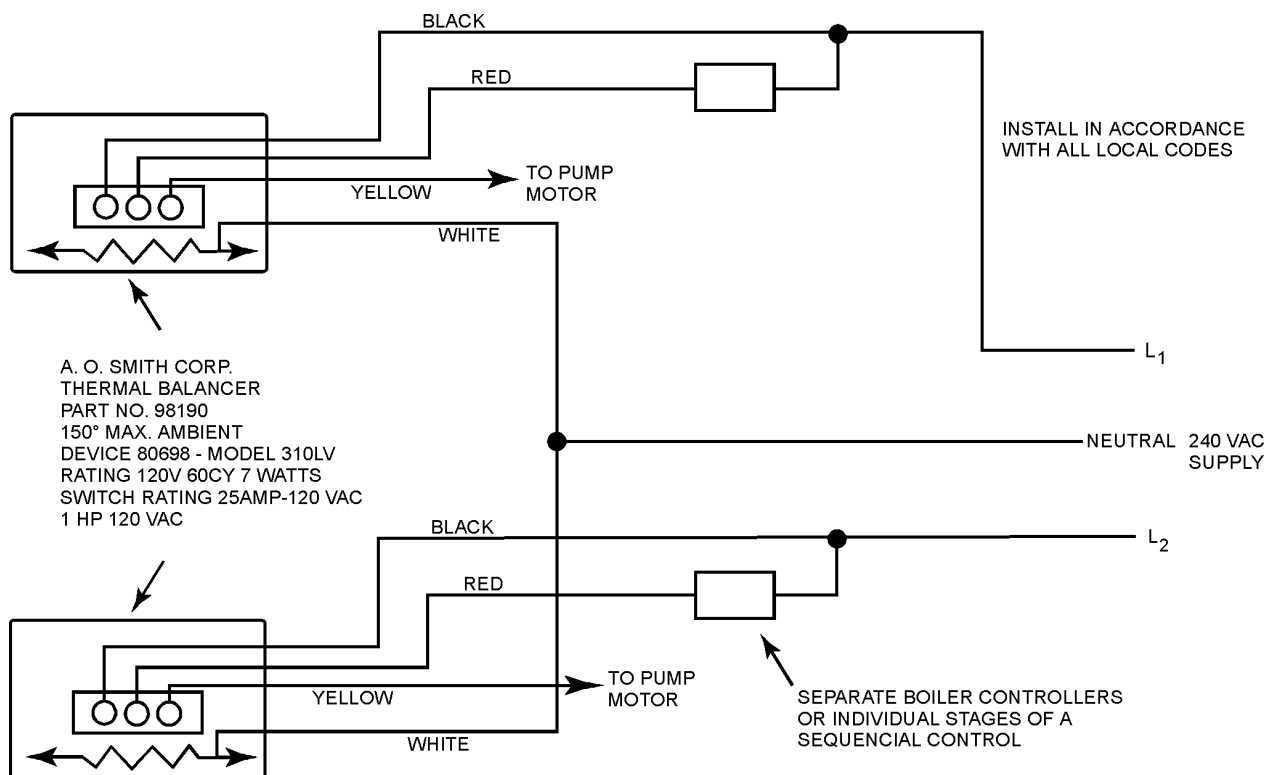

Example of balancing motor loads to both legs of a 240 VAC power supply. This normally is not required for fractional horsepower motors of a LINEAR TEMP system.

