

VERTEX™ 96% THERMAL EFFICIENCY CONTINUOUS HOT WATER VERSATILE POWER DIRECT VENT

Today's homes demand more hot water than ever before, and the 96% efficient Vertex power direct vent gas water heater offers unprecedented levels of performance to meet the need. The 50-gallon Vertex delivers hot water output that exceeds a 75-gallon atmospheric gas water heater. In fact, the fully condensing Vertex design is so advanced, it can deliver "continuous hot water for shower after shower" ... a constant flow of over 4 gallons per minute.* Yet Vertex is easy to install, with height, diameter and installation requirements similar to standard power direct vent units.

HELICAL INTERNAL HEAT EXCHANGER

- Spiral heat exchanger keeps hot combustion gases in the tank longer lengthen the heat transfer cycle
- Positioned in the center of the tank for more even heat distribution
- Operates at 96% thermal efficiency, which saves money on operating costs compared to a standard 78% efficient gas water heater

POWER DIRECT VENT DESIGN

- Uses inexpensive PVC, CPVC or ABS pipe for intake and exhaust. Canadian installations require ULC S636 listed PVC or CPVC pipe for venting
- Can be vented vertically thru-the-roof or horizontally thru-the-wall
- 2" pipe, vents up to 45 equivalent feet
- 3" pipe, vents up to 128 equivalent feet
- Optional concentric vent kit available
- 120v 3-prong power chord

CONDENSING DESIGN

- 96% efficient condensing design
- Equipped with condensate drain tee

SIDE-MOUNTED HOT AND COLD RECIRCULATING TAPS

- Allows Vertex to be installed as part of combination space heating/water heating applications or any system requiring a recirculating hot water loop, including radiant floor heating

ADVANCED ELECTRONIC CONTROL

- Large LCD display
- Precise temperature control
- Advanced diagnostics
- iCOMM™ Compatible and can be monitored from remote locations. Call 1.888.WATER02 for more information.



COMMERCIAL GRADE GLASS LINING

- A. O. Smith PermaGlas® Ultra Coat™ process provides superior protection against corrosion
- Protects all interior tank surfaces including inside and outside of helical heat exchanger

TWO HEAVY-DUTY ANODE RODS

- Provides even more protection against corrosion

TOP FIRED LOW NOx GREEN CHOICE® GAS BURNER

- "Eco-Friendly" design reduces NOx emissions and complies with ultra-low NOx emission standards

CSA CERTIFIED AND ASME RATED T&P RELIEF VALVE

AVAILABLE IN NATURAL GAS OR PROPANE

MAXIMUM HYDROSTATIC WORKING PRESSURE: 150 PSI

* 4.31 GPM continuous flow, based on 65°F inlet water temperature, 110° outlet temperature.

GDHE-50



Series 124/125



Low Lead Content

VERTEX™ 96% THERMAL EFFICIENCY CONTINUOUS HOT WATER VERSATILE POWER DIRECT VENT

CODES AND STANDARDS

- Design-certified by UL (Underwriters Laboratories) according to ANSI Z21.10.3 - 4.3 CSA Standards
- This model meets the thermal efficiency and standby loss requirements of the U.S. Department of Energy and current edition ASHRAE/IESNA 90.1.
- Approved for Canada

SIX-YEAR LIMITED TANK AND PARTS WARRANTY

- For complete warranty details, consult written warranty shipped with heater or contact A. O. Smith

MODEL NUMBER	BTU INPUT PER HOUR	GALLONS or LITRES	FIRST HOUR DELIVERY GALLONS or LITRES	RECOVERY GALLONS or LITRES 90°F / 50°C RISE	SHIPPING WEIGHT LBS / Kg
GDHE-50	100,000	50	164	129	255
		189	621	488	115.7

DIMENSIONS IN INCHES

GDHE-50	A	B	C	D	E	F
INCHES	66-3/4	49-1/4	22	15-3/4	3	8
CM	169.5	125.09	55.88	40	7.62	20.32

Inlet and outlet connections: 3/4" male
 Circulation loop connections: 3/4" female
 Gas inlet: 1/2"
 Maximum Supply Pressure: 14 inches W.C. (3.48kPa)
 Minimum Supply Pressure for Natural Gas: 3.50 inches W.C. (.87kPa)
 Minimum Supply Pressure for Propane Gas: 8.00 inches W.C. (1.99kPa)
 Minimum pressure must be maintained under both load and no load (dynamic and static) conditions.
 Electrical Characteristics - 120V, 60Hz, Amperes <5

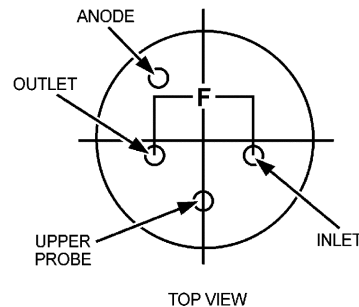
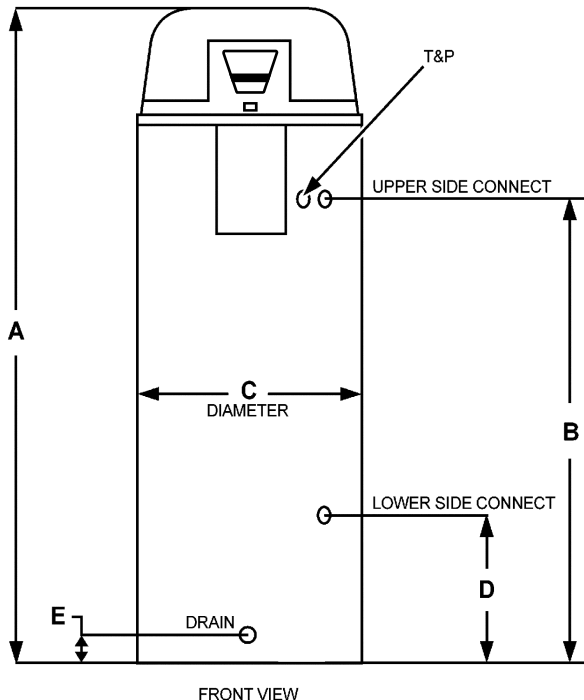

INSTALL IN ACCORDANCE WITH LOCAL CODES.

