

## MASTER-FIT® SERIES - COMMERCIAL GAS WATER HEATERS

### FEATURES

The Master-Fit® BTR-151 and BTR-201 are designed for installation in booster applications, to supply commercial dishwashers with very high temperature water, typically 180°F. A booster water heater is generally used in conjunction with a standard water heater water delivering hot water at a lower temperature to meet the non-dishwashing needs of a restaurant or other foodservice application.

With a 32-gallon storage tank, these compact units measure only 45" high with a hot water outlet in the top and both top and cold water inlets in the front.

#### THE ELIMINATOR™SELF-CLEANING SYSTEM

- Designed to significantly reduce or eliminate buildup of lime, sand and other sediment inside the tank
- Reduced sediment buildup helps Master-Fit water heaters maintain their rated energy efficiency and reduce water heating costs
- Self-cleaning system also helps prolong tank life

#### BUILT-IN INDUCED DRAFT BLOWER

- Produces power-induced draft of makeup air prior to burner ignition
- Provides more efficient control of heat through the flue collector
- No draft hood or barometric damper required

#### RATED AS CATEGORY 1 APPLIANCE

- Can be commonly vented with other Category 1 appliances, using standard metal type "B" vent

#### PERMAGLAS® ULTRA COAT GLASS LINING

- Exclusive process provides superior protection against corrosion
- CoreGard anode rods with stainless steel core provide additional corrosion protection
- The Eliminator self-cleaning device operates when cold water is connected through front

#### INTERMITTENT ELECTRONIC IGNITION

- Eliminates standing pilot
- Includes power ON/OFF switch
- Provides flame failure response in less than one second

#### CSA CERTIFIED AND ASME RATED T&P RELIEF VALVE

#### MAXIMUM HYDROSTATIC WORKING PRESSURE 160 PSI

#### 80% THERMAL EFFICIENCY CODES AND STANDARDS

- Design-certified by UL (Underwriters Laboratories), according to ANSI Z21.10.3 - CSA 4.3 standards governing storage-type water heaters
- Listed By UL Sanitation as complying with ANSI/NSF-5
- Meets or exceeds the thermal efficiency and standby loss requirements of the U. S. Department of Energy and current edition of ASHRAE/IESNA 90.1
- Optional ASME construction available

#### WARRANTY

- Three-year limited warranty against tank leaks
- For complete warranty information, consult written warranty shipped with water heater, or contact A. O. Smith Water Products Company

## BTR-151(A) through BTR-201(A)



ASME/CRN  
(OPTIONAL)



### CAPACITY, INPUT AND OUTPUT

MODEL NUMBER	BTU INPUT PER HOUR	Gallons or Litres	TANK SIZE	FIRST HOUR RATING	GPH or LPH	RECOVERY-GALLONS or LITRES PER HOUR AT DEGREE RISE				
						40°F	60°F	80°F	100°F	140°F
						22°C	33°C	44°C	56°C	78°C
BTR-151	150,000	U.S.Gallons	32	167	GPH	364	242	182	145	104
		Litres	121.1	632.1	LPH	1377.7	916	688.9	548.8	393.6
BTR-201	199,900	U.S.Gallons	32	216	GPH	485	322	241	194	139
		Litres	121.1	817.6	LPH	1835.7	1218.8	912.2	734.3	526.1

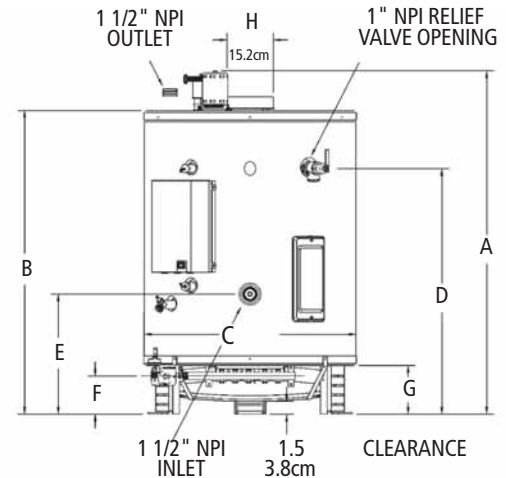

### CAPACITY, INPUT AND OUTPUT

MODEL NUMBER		DIMENSIONS								GAS CONN.	WATER CONN.	APPROX. SHIPPING WEIGHT (IBS.) STD/ASME
		A	B	C	D	E	F	G	H			
BTR-151(A) and BTR-201(A)	inches	45	40	27-3/4	32-1/4	15-3/4	5	6-1/2	6	3/4	1-1/2	460/440
	cm	114.3	101.6	70.5	81.9	40	12.7	16.5	15.2	3/4	1-1/2	181.8

### SUGGESTED SPECIFICATION

Gas booster water heater(s) shall be A. O. Smith Master-Fit, Model Number \_\_\_\_\_, with a 32-gallon storage capacity, an input rate of \_\_\_\_\_ BTU/HR, \_\_\_\_\_ gas, and a recovery rate of \_\_\_\_\_ gallons per hour at a \_\_\_\_\_ degree Fahrenheit temperature rise, and a maximum hydrostatic working pressure of 160 psi. Unit(s) shall have a fan-assisted combustion system, providing a power-induced draft of makeup air prior to burner ignition. Unit(s) shall be equipped with intermittent electronic ignition with power on/off switch, which shall provide flame failure response in less than one second. The burner for the unit(s) shall be easily removable. Unit(s) shall be equipped with a CSA Certified and ASME Rated T&P relief valve, and a 2-3/4' x 3-3/4' tank inspection port. The water heater tank shall be glasslined and protected against premature failure in the following ways: 1. Against electrolytic corrosion by multiple, factory-installed anode rods 2. Against failure due to overheating caused by the buildup of scale, film and other sediment by a self-cleaning device, positioned inside the tank so that it directs the flow of inlet water in such a way that microscopic particles of precipitated solids shall be kept in suspension and exhausted from the water heater on that or successive hot water draws. Unit(s) shall be UL listed to comply with ANSI/NSF-5 for Sanitation. Unit(s) shall meet or exceed the thermal efficiency and standby loss requirements of the U. S. Department of Energy and current edition of ASHRAE/IESNA 90.1, and be design certified by UL (Underwriters Laboratories), according to ANSI Z21.10.3 - CSA 4.3 standards governing storage-type water heaters.