

### *Burkay* **GENESIS**

#### **84% EFFICIENT, LOW-NO<sub>x</sub> HOT WATER SUPPLY BOILERS**

#### **FEATURES**

A. O. Smith Genesis® boilers offer everything you could ask for in a non-condensing boiler. They provide the highest possible 84% thermal efficiency, outstanding venting flexibility, space-saving stackable design and a new, advanced Energy Management Control (EMC) system. Genesis models are available for installation indoors (GW Series) or outdoors (GWO Series).

#### **NEW EMC-5000 ENERGY MANAGEMENT CONTROL**

- Patent pending
- Controls every electrical boiler function, including pump operation and main burner ignition, delivers precise temperature management, with  $\pm 1^\circ$  accuracy
- Display panel shows current operating status and fault readings in easy-to-understand English instead of confusing numeric codes
- Display also shows temperature setpoints, outlet temperature, current inlet/outlet differential ( $\Delta T$ ) and tank temperature
- Help screens assist in boiler setup and explain control options
- Included remote temperature sensor when mounted in the storage tank allows the tank temperature to be set and monitored at the boiler

#### **TWO-STAGE GAS FIRING SYSTEM**

- Twin gas valve firing system prevents short cycling and ensures smooth operation, saves fuel and extends boiler life
- Prevents short cycling when demand is low, delivers maximum output when demand is high

#### **LOW-NO<sub>x</sub> OPERATION**

- Meets or exceeds Texas and California SCAQMD Rule 1146.2 air quality standards

#### **COPPER FINNED-TUBE HEAT EXCHANGER**

- Designed for maximum durability and serviceability
- Copper is lightweight for easier handling and immune to thermal shock
- Removable headers allow easy inspection of waterways

#### **SPACE-SAVING DESIGN**

- Smaller footprint versus other horizontal copper fin-tube boilers
- Optional stack rack allows one unit to be stacked on top of another, doubling output within the footprint of a single unit

#### **MEETS ASHRAE/IESNA 90.1-2004**

#### **FIVE-YEAR HEAT EXCHANGER LIMITED WARRANTY**

- For complete information, consult written warranty or contact A. O. Smith

### **MODELS GW/GWO-300 THROUGH GW/GWO-750**

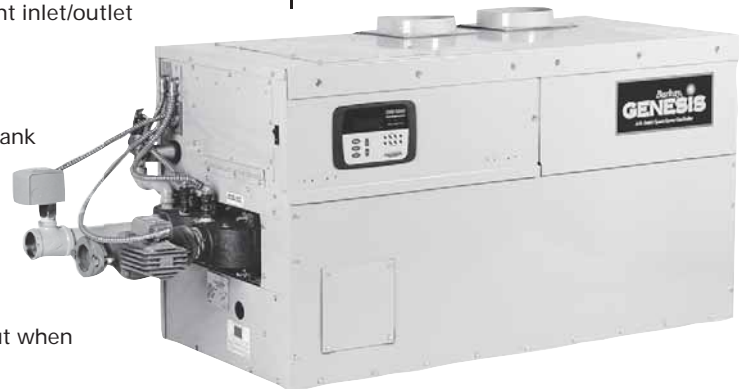

**ASME**



### GW SERIES INDOOR MODELS

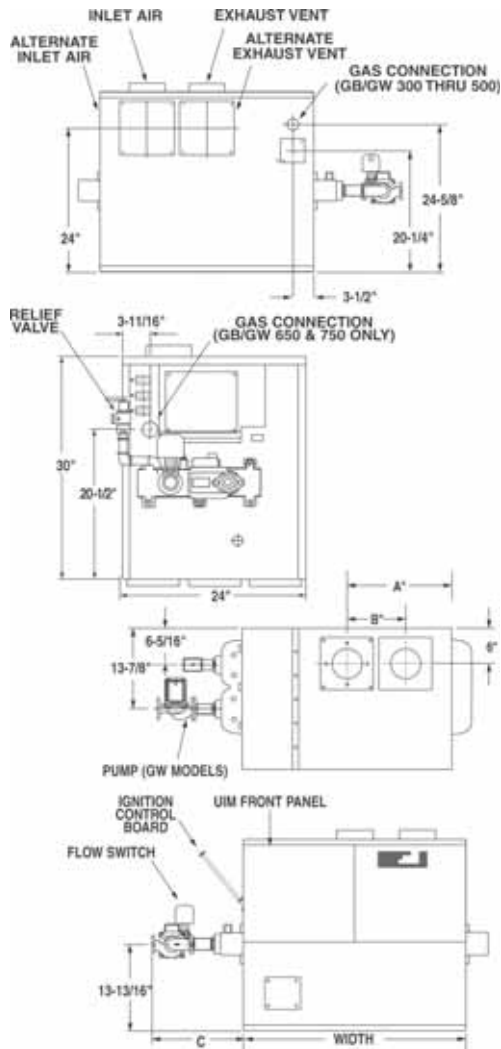

### GWO SERIES OUTDOOR MODELS

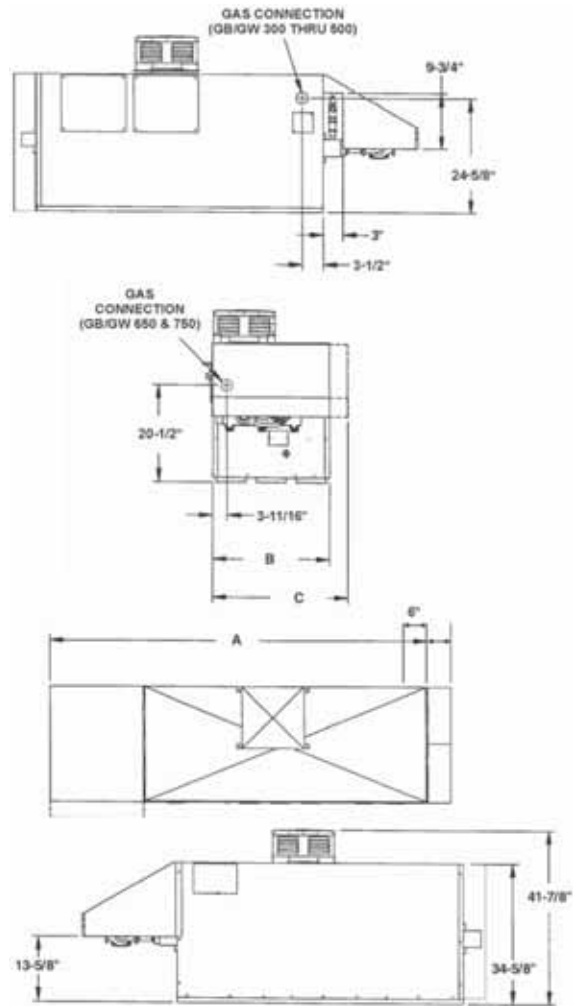

MODEL NUMBER	BTU INPUT PER HOUR	DIMENSIONS IN INCHES							
		EXHAUST VENT	AIR INLET	WATER CONN.	GAS PIPE	(SEE DRAWINGS ABOVE)			
						WIDTH	A	B	C
<b>GW SERIES INDOOR MODELS</b>									
GW-300	300,000	5	5	1-1/2	3/4	29-1/2	14-13/16	9	12
GW-400	399,900	6	6	1-1/2	1	35-3/4	17-15/16	9	14-3/4
GW-500	500,000	6	6	2	1	42	21-1/16	9	14-3/4
GW-650	650,000	8	8	2	1-1/4	51-3/8	25-3/4	9	14-3/4
GW-750	750,000	8	8	2	1-1/4	57-3/8	28-7/8	9	17-1/4
<b>GWO SERIES OUTDOOR MODELS</b>									
GW-300	300,000	-	-	1-1/2	3/4	-	49	24-3/16	-
GW-400	400,900	-	-	1-1/2	1	-	55-1/4	24-3/16	-
GW-500	500,000	-	-	2	1	-	61-1/2	24-3/16	-
GW-650	650,000	-	-	2	1-1/4	-	70-7/8	-	27-11/16
GW-750	750,000	-	-	2	1-1/4	-	77-1/8	-	27-11/16

## OTHER GENESIS® FEATURES

### FACTORY-INSTALLED CIRCULATING PUMP

- Pre-wired, integrally controlled by EMC-5000 control
- Adjustable pump time delay allows removal of usable residual heat during stand-by cycle, virtually eliminating stand-by heat loss

- **ASME PRESSURE RELIEF VALVE 125#**
- **FACTORY INSTALLED FLOW SWITCH**
- **ALTERNATE THERMOSTAT TERMINALS (24V)**
- **MANUAL RESET HIGH LIMIT**
- **BLOCKED FLUE SWITCH**
- **BLOCKED INLET SWITCH**
- **AIR PROVING SWITCH**

### GENESIS® OPTIONS

- CSD-1 CODE
- NEW YORK CODE
- CALIFORNIA CODE
- ALARM BELL
- ALL-BRONZE CIRCULATING PUMP
- HARD WATER PUMP
- BRONZE HEADERS
- STACK RACK
- LOW WATER CUT-OFF
- EXTENDED VENTING KIT
- SEQUENCING CONTROL PANEL (FOR 2-8 BOILERS)
- COMBUSTIBLE FLOOR SHIELD
- DRY CONTACTS FOR ANY BOILER FAILURE
- CUPRO-NICKEL HEAT EXCHANGER
- CSA CERTIFIED VENT KIT

## GENESIS® VENTING VERSATILITY

### DIRECT-VENTING

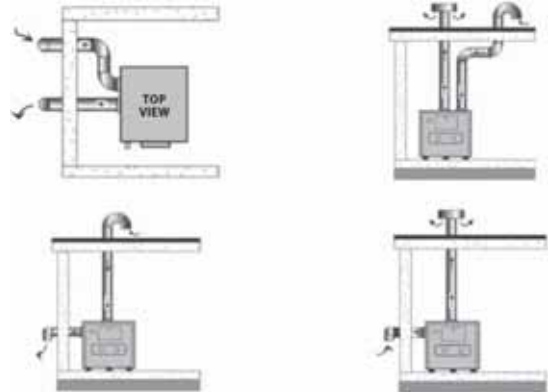

### SIDEWALL VENTING

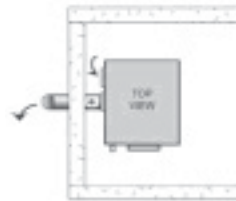

### CONVENTIONAL VENTING

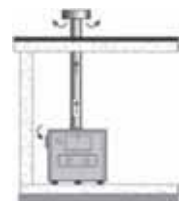

For the most current Genesis venting distances/information, consult the Genesis Product Manual, available through your local A. O. Smith representative, or online at [www.hotwater.com](http://www.hotwater.com).

MODEL NUMBER	BTU INPUT PER HOUR	RECOVERY — GALLONS PER HOUR AT °F TEMPERATURE RISE										
		40°	50°	60°	70°	80°	90°	100°	110°	120°	130°	140°
GW/GWO-300	300,000	761	609	507	435	380	338	304	277	254	234	217
GW/GWO-400	399,900	1014	811	676	580	507	451	406	369	338	312	290
GW/GWO-500	500,000	1268	1015	845	725	634	564	507	461	423	390	362
GW/GWO-650	650,000	1649	1319	1099	942	824	733	659	600	600	507	471
GW/GWO-750	750,000	1902	1522	1268	1087	951	845	761	692	634	585	544

Gas Supply Pressure: 13.8" W.C. maximum natural and propane; 4.5" W.C. minimum natural; 11.0" W.C. minimum propane.  
 Genesis boilers are approved for installation on noncombustible flooring in an alcove with minimum clearance to combustibles of: 3 inches sides, and back; 3 inches top, front alcove; 6 inches vent.  
 For installation on combustible flooring use the optional Combustible Floor Kit.  
 Genesis boilers must be connected to a single phase dedicated line source that is: 120 volts, 60 hertz and 20 amps.



# Commercial Gas Boilers

## SUGGESTED SPECIFICATION

The hot water supply boiler(s) shall be an A. O. Smith Genesis® Model GW \_\_\_\_\_ having an input rating of \_\_\_\_\_ BTU/hr. and capable of supplying no less than \_\_\_\_\_ GPH at a 100°F temperature rise when fired with Natural/Propane gas. The boiler shall bear the ASME "H" stamp and shall be National Board registered for 160 PSI working pressure. The boiler shall be test certified at 84% thermal efficiency by CSA per ANSI Z21.13/CSA 4.9 Harmonized Standard Latest Addenda. The boiler's copper fin tube heat exchanger shall be a horizontal, single row, two pass design. The solid copper tubes shall have integral extruded copper fins spaced at "7" fins per inch, and be rolled into heavy steel tube sheets. High temperature silicone "O" rings shall provide a watertight seal between each tube and the ASME code Bronze/Cast Iron headers. Headers must be field removable to allow complete inspection of all waterways. Non-removable headers, with tubes rolled directly into the headers, shall not be acceptable. The low mass, low water volume heat exchanger shall be explosion-proof and immune to thermal shock.

The combustion chamber shall be fully lined with high temperature ceramic fiber insulation, rated to 2,300°F. The jacket panels shall be coated with a baked-on powder-coat finish, suitable for outdoor service. The jacket shall be of tight construction, and weather- and water-resistant.

The hot water supply boiler(s) shall be supplied with a factory supplied, sized and wired boiler-circulating pump.

The boiler shall employ a fan induced premixed multi-burner system firing into a pressurized combustion chamber. Atmospheric or power burners will not be acceptable. Only stainless steel/titanium alloy burners will be acceptable. All boiler functions shall be controlled, operated, and monitored by a microprocessor-based control. The microprocessor shall control the boiler temperature and be accurate to within plus or minus 1°F. The hot surface ignition system shall employ a separate flame sensor for maximum reliability.

The boiler shall be supplied with a remote tank thermistor for sensing and controlling the hot water storage tank temperature up to 1,000 feet away. Provisions for connecting a remote thermistor, alarm bell, pump, and alternate temperature controller must be provided.

Factory mounted and wired flow, blower prover, and blocked flue switches shall be provided. The gas train shall meet or exceed the requirements of ANSI Z21.13 and include gas pressure regulator, manual gas cock, redundant safety gas valve, operating control valve, and plugged pressure test tapings. The ASME rated pressure relief shall be factory installed.

The boiler shall be certified for direct horizontal through-the-wall venting, or direct vertical venting; in addition to sidewall or conventional vertical venting. The boiler must be field convertible from top mounted venting to rear mounted venting. The boiler shall be capable of horizontal sidewall or direct venting up to 35 equivalent feet without the aid of any optional sidewall vent fans or blowers.