

CONSERVATIONIST® Burkay®

ALL NON-FERROUS WATERWAYS

- All castings are made of Bronze or Brass. All water tubes are made from copper. Brazed joints or flare union construction make the heater immune to the effects of thermal shock and thermal cycling. The Burkay® boiler provides one of the smallest foot prints in the industry. Ideal for multiple boiler applications.

EFFICIENT COPPER COIL COMBUSTION CHAMBER

- The combustion chamber is a heat exchanger formed from a two passage coil of tightly wound continuous copper tube. Water circulating through this coil captures radiant heat. A wrap of insulation on the outside of the coil retains the heat captured by the circulating water.
- Up to 82% efficient

COPPER HEAT EXCHANGER

- Directly above the coil and the main burner is a compact, horizontal, copper fin tube heat exchanger. The flue gases must pass through this efficient heat exchanger before leaving the boiler. This unique Burkay coil and heat exchanger design provide maximum heat transfer and proven field durability.

MODELS MEET OR EXCEED THE THERMAL EFFICIENCY AND STANDBY LOSS REQUIREMENTS OF THE U. S. DEPARTMENT OF ENERGY AND CURRENT EDITION OF ASHRAE/IESNA 90.1

BURKAY BURNER MAXIMIZES EFFICIENCY

- The patented Burkay® burner uses primary air injection at up to 72 individual orifices plus secondary entrainment of air.

GAS VALVES

- Step opening or slow opening redundant gas valves ensure smooth light-off without flame roll-out or pilot outage.

THERMAL BALANCER

- Factory supplied for use with primary secondary heating systems. Cycles the secondary pump with the burner, but delays pump shut off at the end of the heating cycle to remove usable heat from the boiler. Virtually eliminates stand-by heat losses at the boiler.

AUTOMATIC SAFETY CONTROLS AND ELECTRONIC IGNITION

- Proven pilot ignition system provides flame failure response in under one (1) second. Redundant high limit controls and gas valves assure safe shut off in the event of overheating or flame failure. Requires 120V 60Hz. Maximum inlet gas pressure 14" W.C. Minimum gas pressure 4.5" W.C. Requires remote temperature system control: loop stat, energy management system, Indoor/ Outdoor Reset control. (Not furnished with the boiler.)

WORKING PRESSURE

- ASME approved, hydrostatically tested and certified for 160 psi. Supplied with ASME relief valve 50#.

OPTIONAL EQUIPMENT

- CSD-1 code, California code, New York code, Low Water Cutoff, Indoor/Outdoor Reset and Sequencing Panel (1-8 Boilers).

LIMITED WARRANTY OUTLINE

- If the coil, heat exchanger or burner should fail within 10 years, under the terms of the warranty, A. O. Smith will furnish a replacement part; installation, labor, handling and local delivery extra. When used for hot water supply or swimming pool application, the coil, heat exchanger and burner warranty is 5 years. This outline is not a warranty. For complete information, consult the written warranty or A. O. Smith Water Products Company.

Not approved for instantaneous applications.

HW-300 THRU HW-670



APPROVED





Hydronic Heating Boilers

CONSERVATIONIST® Burkay®

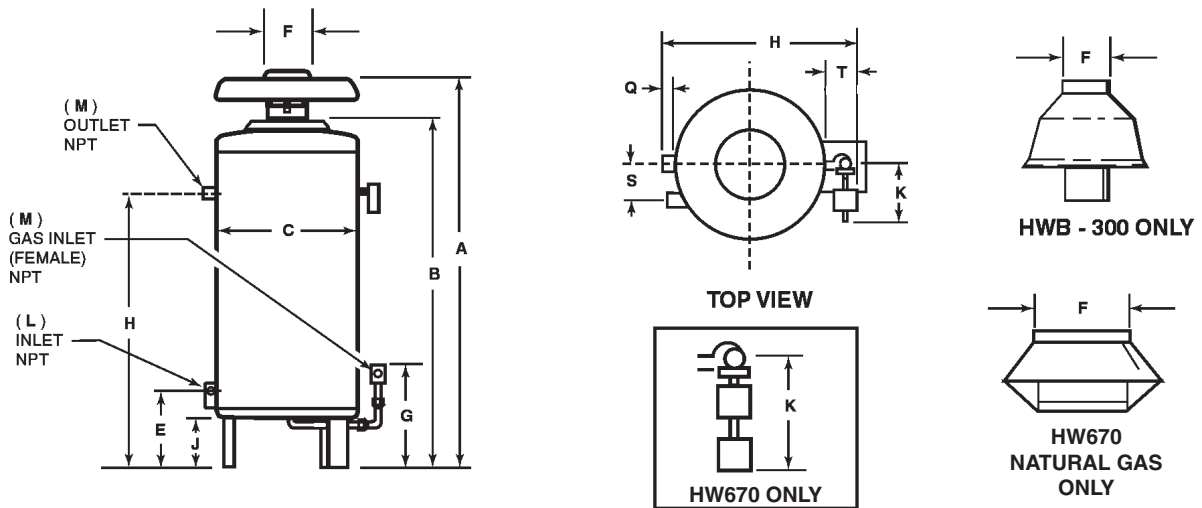

Models	A	B	C	D	E	F	G	H	J	K	L	M	N	Q	S	T	Approx. Ship. Wt. Lbs.
HW-300	65	43-1/4	36	25-1/4	12	8	16-1/2	29-5/8	9	14	1-1/4	1-1/4	3/4	1	5-3/8	5	240
HW-399	57-1/8	45-1/8	38-3/4	27	12	10	16-3/4	31-1/2	9	14	1-1/2	1-1/2	1	1	5-1/2	5	291
HW-420	57-1/8	45-1/8	38-3/4	27	12	10	16-3/4	31-1/2	9	14	1-1/2	1-1/2	1	1	5-1/2	5	291
HW-520	68-5/16	56-1/4	46	27	12	10	18	36-1/2	9	11	2	2	1	3-1/2	5-3/4	7	361
Prop.																	
HW-670	67	56-1/4	46	27	12	12	18	36-1/2	9	11	2	2	1	3-1/2	5-3/4	7	361
Nat.																	
HW-670	67	56-1/4	46	27	12	12	18	36-1/2	9	11	2	2	1	3-1/2	5-3/4	7	361

Models	BTU Input/Output		Temperature Rise and Pressure Drop					
	Input Rating BTU/Hr. Natural & Propane (LP) Gas	Output Rating BTU/Hr. Natural & Propane (LP) Gas	20 Deg. F Rise		30 Deg. F Rise		40 Deg. F Rise	
			GPM	PD-Ft. Head	GPM	PD-Ft. Head	GPM	PD-Ft. Head
HW-300	300,000	247,200	23	8	15	3	11	2
HW-399	399,000	322,790	30	16	20	7	15	5
HW-420	420,000	344,400	32	18	21	8	16	5.5
HW-520	520,000	429,000	39	12	24	5	20	4
HW-670 Nat.	660,000	543,000	51	22	34	10	25	5.5
HW-670 LP	670,000	536,455	54	22	34	10	25	5.5

NOTE: To compensate for the effects of high altitude areas above 2,000 feet, the input, output, and heating load ratings should be reduced approximately 4% for each 1,000 feet above sea level.

SUGGESTED SPECIFICATIONS

The hydronic heating boiler(s) shall be an A. O. Smith Model HW _____ having an input rating of _____ BTU/hr., an output rating of _____ BTU/hr., when fired using Natural/Propane gas. The boiler(s) shall be design certified by an ANSI approved/accredited independent rating laboratory. The boiler shall bear the ASME "H" stamp and shall be National Board registered for 160 PSI working pressure. Boiler(s) shall be up flow type having all non-ferrous waterways, and employing a copper finned heat exchanger and a tightly wound copper coil combustion chamber. Boiler(s) shall be equipped with an electric gas valve of the step-opening type, an adjustable limit control which will break the electric circuit on temperature rise, intermittent ignition with one (1) second shutdown in the event of pilot flame failure, a gas pressure regulator properly set for the gas to be supplied, and a coil limit switch for shut off in event of excessive water temperature, a certified draft diverter and a fully illustrated instruction manual. Certified for combustible flooring. Outer jacket shall be of baked enamel finish. The coil, heat exchanger and burner shall have a ten year limited warranty as outlined in the written warranty.

For Technical Information and Automated Fax Service, call 800-527-1953. A. O. Smith Corporation reserves the right to make product changes or improvements without prior notice.