

HW-120M AND HW-160M WITH OR WITHOUT IID SYSTEM WITHOUT THERMAL BALANCER

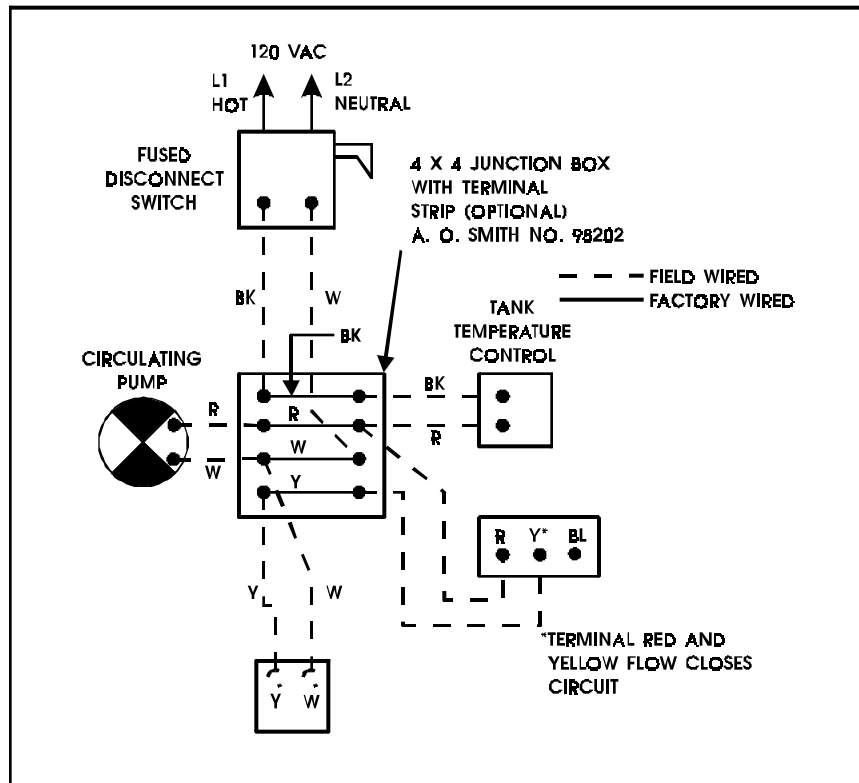

HW-200M THRU 670 STANDING PILOT AND IID SYSTEMS AND THERMAL BALANCER

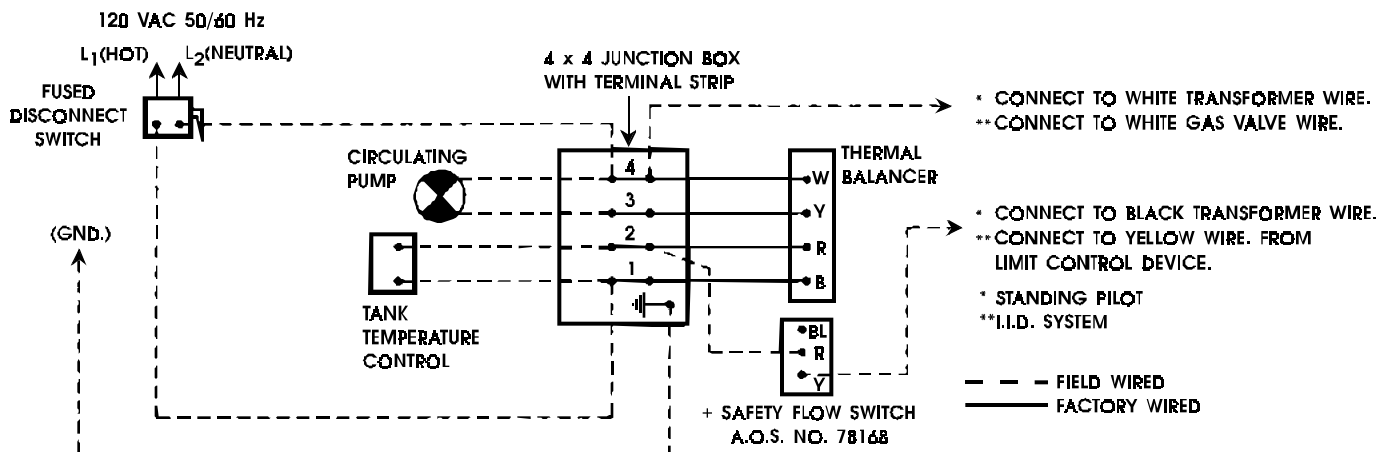

WIRING DIAGRAMS
CER-TEMP 80 — TWO UNITS

A.O. SMITH

HW-200M THRU HW-670
WITH IID SYSTEM
(ONE PUMP)

