

## VOLTEX® HYBRID ELECTRIC WATER HEATERS

Voltex Hybrid Electric heat pump water heaters from A. O. Smith are the most versatile, energy-efficient option for the consumer who is looking to go green and save some green. Voltex can provide the same amount of hot water as a conventional electric water heater at half the cost.

### HOW DO THEY WORK?

- Absorb ambient heat from the surrounding air to heat water using a compressor and “Environmentally-Friendly” R134a refrigerant
  - Self-contained heat pump unit is integrated into the top of the tank
  - Multiple operating modes maximize efficiency and meet increasing hot water needs

### QUALIFIES FOR 2010 FEDERAL TAX CREDIT OF UP TO \$1,500

## FEATURES

### INCREASED STORAGE

- High capacity storage tank enables the heat pump to operate more frequently than the heating elements. This provides higher energy efficiency and lower operating costs, saving money for the home owner
- High capacity storage tank provides more hot water for peak demand periods

### ENERGY EFFICIENCY

- Up to a 2.4 Energy Factor (EF) Rating conserves energy and meets ENERGY STAR® qualifications

### CHOICE OF OPERATING MODES

- Select from Efficiency, Hybrid, or conventional Electric modes to match heating requirements to environmental conditions. Hybrid mode automatically adjusts between compressor and element, depending upon heat requirements. Vacation mode reduces operating costs and provides freeze protection during extended absence.

### BACKUP ELECTRIC ELEMENTS

- Long-lasting incoloy heating elements, 240V/2000W lower and 240V/4500W upper, helps heat water when in conventional Electric or Hybrid modes

### DRY FIRE PROTECTION

- Control system checks to ensure the tank is full of water during start up to prevent dry firing the heating elements

### ELECTRONIC USER INTERFACE

- User-friendly LCD touch pad control with plain English text and intuitive status icons provides easy interaction
- Large LCD temperature display (see back) shows temperature in °F or °C
- 3 line 13 character backlit LCD display communicates current set point, status and operational information
- Advanced diagnostics convey error messages in plain English. The last four error messages are saved in the control system memory.
- Child resistant safety lock deters unwanted access to temperature settings

### POWERED ANODE

- A non-sacrificial powered anode protects the tank from corrosion and eliminates the service requirements of conventional anode rods.

### DEHUMIDIFICATION

- Ideal for basements or garage installations; the compressor transfers heat to the water while dehumidifying and cooling the ambient air.
- Washable air filter is easily removed for routine cleaning

### TEN YEAR LIMITED WARRANTY

- For complete information, consult written warranty or contact A. O. Smith Water Products Company



**MODEL SHOWN  
PHPT-80**



Low Lead Compliant



# Residential Hybrid Electric Heat Pump Water Heaters



### ELECTRONIC USER INTERFACE

- Large LCD touch pad display
- Intuitive icons clearly indicate the current operating mode
- Individual backlit buttons for mode selection:
  - Efficiency
  - Hybrid
  - Electric
  - Vacation
- Three-line display communicates current status and displays error messages in plain English when applicable
- Safety lock

### EFFICIENCY MODE

- Utilizes the heat pump for all water heating
- Automatically reverts to heating element if ambient air or water temperatures are outside optimal operating range for heat pump

### HYBRID MODE

- Utilizes the heat pump or heating element, depending on demand

### ELECTRIC MODE

- Standard electric water heater operation

### VACATION MODE

- One touch operation maintains tank temperature of 60° F (15.6° C) during vacation or extended absence to reduce operating costs and provide freeze protection

MODEL	GALLON CAPACITY	ENERGY FACTOR BY MODE			1ST HOUR RATING BY MODE			HEIGHT (Inches)	DIAMETER (Inches)	HEIGHT TO WATER OUTLET (Inches)	HEIGHT TO WATER INLET (Inches)	HEIGHT TO T&P (Inches)	Approximate Shipping Weight (LBS)
		EFFICIENCY*	HYBRID	ELECTRIC	EFFICIENCY	HYBRID	ELECTRIC						
PHPT-60	60	2.40	2.33	0.88	51	68	66	67-1/3	24-1/2	41	4-1/4	40	332
PHPT-80	80	2.30	2.33	0.85	70	84	76	81-1/2	24-1/2	55	4-1/4	56-1/3	410

\*Up to a 2.4 Energy Factor (EF) rating in Efficiency mode.

### OTHER FEATURES:

- Powered anode to protect against tank corrosion (Max 50 mA draw)
- 2 Inch "Environmentally-Friendly" non-CFC foam insulation
- Coefficient of performance (COP) 3.1
- Child resistant brass drain valve
- CSA certified and ASME rated T&P relief valve
- Water temperature set point range; 95°F to 150°F (35°C to 66°C)

### OPERATING REQUIREMENTS:

- Requires provision for condensate draining; if a suitable drain is not available a condensate pump is required
- Recommended minimum 750 cubic feet of space for air circulation/heat exchange
- 240 VAC single phase power supply with 25 amp circuit breaker

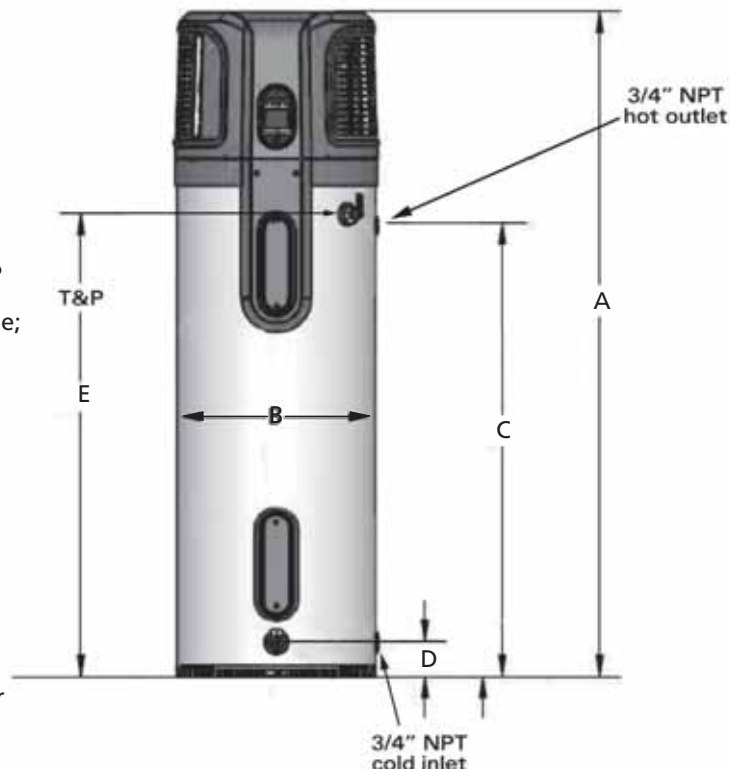

For Technical Information and Automated Fax Service, call 800-527-1953. A. O. Smith reserves the right to make product changes or improvements without prior notice.