

## CONSERVATIONIST® - POWER VENT SINGLE FLUE MODEL

### APPROVAL RATINGS AND CERTIFICATION

All models comply with: ANSI Z21.10.3 and ASHRAE/IES 90.1 – 2004

All models comply with SCAQMD Natural Gas NOx rule 1121 or 1146.2.

All models are approved for use in combined appliance applications.

### FEATURES

**CFC-FREE FOAM INSULATION** – Minimizes radiant heat loss.

**DIP TUBE** – Carries inlet water deep into tank.

**HOT SURFACE IGNITION** – Has a solid state ignition surface that does not flutter or blow out. Provides increased reliability and efficiency over spark ignition systems. Eliminates the pilot and saves energy.

**INTELLI-VENT CONTROL** – Provides temperature control and LED diagnostics.

**GLASS-LINED TANK** – Glass specifically developed by A. O. Smith for water heaters is permanently fused to steel at 1,600° F, providing years of corrosion protection and dependable use.

**ANODE** – Tank-mounted, screw-in replaceable anode for longer tank life.

**HIGH INPUT** – 80,000 BTU input assures plenty of hot water is available by providing faster recovery rates and higher first hour draws.

**BURNER** – High input, multiport burner for improved combustion efficiency and low NOx.

**TURBO SHOT™ COMBUSTION SYSTEM** – Air is precisely drawn through the combustion control port and exhausted through plastic pipe. Controlling the airflow through the heater enhances and regulates the combustion process. In standby mode, the combustion control port restricts air circulation through the heater.

**POWERED VENTING** – Provides more venting flexibility and savings. A new quiet blower allows exhaust venting through the roof or sidewall with plastic pipe such as PVC, CPVC, and ABS. Allowable vent lengths of up to 100 equivalent feet make installation easy in any situation. BTF-80 is a Category 3 (positive pressure non-condensing) appliance.

**BUILT-IN CONDENSATE FITTING** – A condensate management coupling that attaches vent pipe to the blower and drain hose are included.

**INSTALLED TEMPERATURE & PRESSURE RELIEF VALVE** – Factory installed and matched to the heater. (Specify if your local code requires a special T&P).

- Three year limited tank warranty - For complete warranty information, consult written warranty or contact A. O. Smith.

## MODEL BTF-80



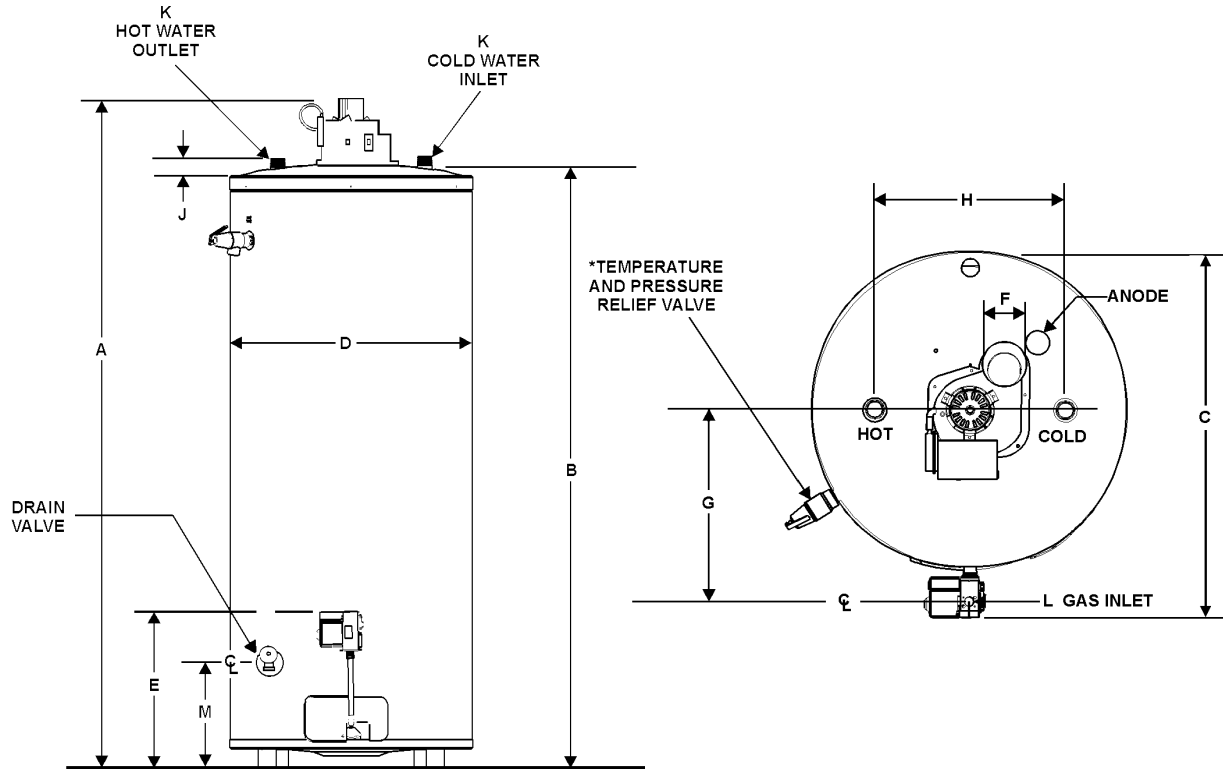

Model	Units	A	B	C	D	E	F	G	H	J	K	L	M
BTF-80	Inches	68	57 1/4	29 5/8	25 3/8	15	4	15 5/8	16	2	1	1/2	11 15/16
	cm	172.7	145.4	75.2	64.5	38.1	10.2	39.7	40.6	5.1	NPT	NPT	30.3

### RECOVERY CAPACITIES U.S. Gallons/Hrs. and Litres/Hr. at TEMPERATURE RISE INDICATED

Model	Input		Approx. Capacity		F°	30F°	40F°	50F°	60F°	70F°	80F°	90F°	100F°	110F°	120F°	130F°	140F°
	Btuh	KW	U.S. Gals.	Litres	C°	17C°	22C°	28C°	33C°	39C°	44C°	50C°	56C°	61C°	67C°	72C°	78C°
BTF-80	80,000	---	74	---	GPH	259	194	155	129	111	97	86	78	71	65	60	55
		23.4	---	280	LPH	979	734	587	489	419	367	326	294	267	245	226	210

Recovery capacity based on 80% thermal efficiency.

### SUGGESTED SPECIFICATION

Water Heater(s) shall be power vent model no. \_\_\_\_\_ as manufactured by A. O. Smith or an approved equal. Heater(s) shall be internally glass-lined and gas-fired, equipped to burn \_\_\_\_\_ gas, and design-certified to the latest ANSI Standard by the CSA International. Rating of \_\_\_\_\_ Gallons and an input rating of \_\_\_\_\_ BTU/HR with a recovery capacity of \_\_\_\_\_ GPH at 100° F. Waters heaters must be certified for power venting applications using standard PVC, class 160, schedule 40, ABS or CPVC vent piping. The water heater shall include a 6' plug-in cord and provision for direct connection to standard electrical conduit. Blower shall include pressure switches which will shut down power to the burner in case of vent system failure due to down drafts or vent blockage. Heater shall have a maximum working pressure of 150 psi, and a nominal storage tank capacity of \_\_\_\_\_ gallons with a 3/4" relief valve opening. Heater(s) shall also be equipped with an automatic shut off device to shut off entire gas supply in event of excessive temperature in tank. Outer jacket shall have a baked enamel finish.